

1 2 3 4 5 6 7 8

REVISIONS		
ISS	ZONE	DESCRIPTION\PER REQUEST\DATE
B	A-1	NO.3 WAS CHANGED\RD-DM88090201B\09-02-99'

業務部

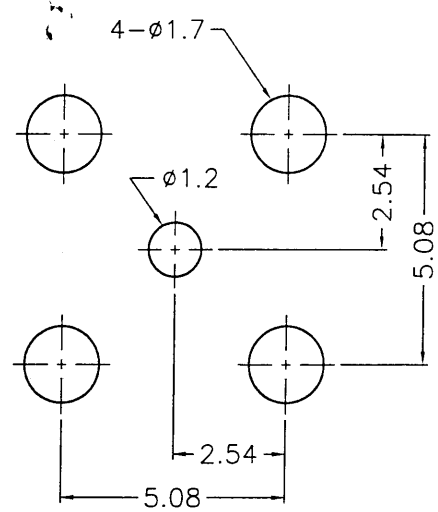
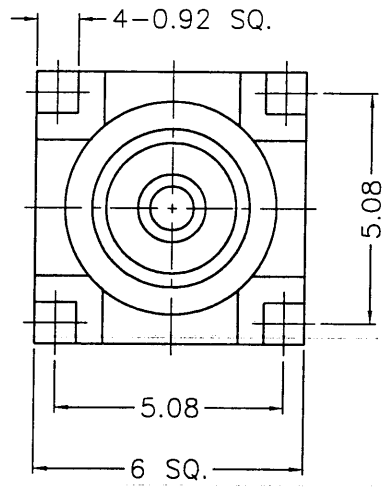
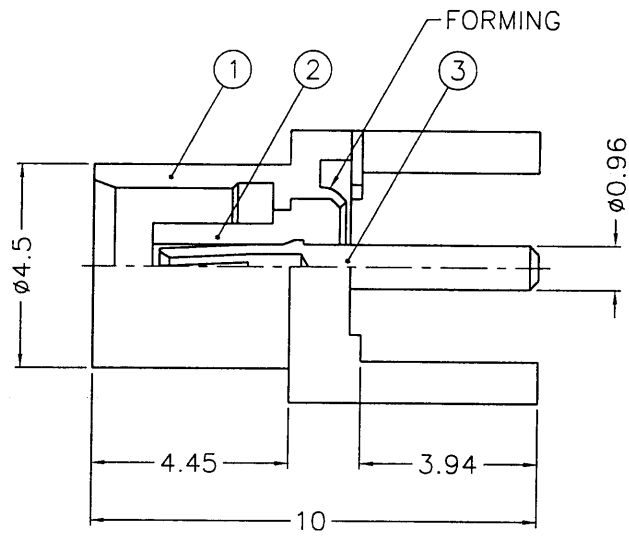

PCB MOUNTING HOLES
(印刷电路板架設孔)

88.9.09
D

- NOTES: FINISH (PLATING THICKNESS IN MICRO-INCHES)
1. BRASS PER QQ-B-626
 2. GOLD PL. 3 MIN. THICK OVER NICKEL PL. 100 MIN. THICK OVER COPPER STRIKE
 3. BERYLLIUM COPPER PER QQ-C-530
 4. GOLD PL. 30 MIN. THICK OVER NICKEL PL. 100 MIN. THICK OVER COPPER STRIKE
 5. TEFLON MIL-P-19468

DIMENSIONS ARE IN MILLIMETERS
UNLESS OTHERWISE SPECIFIED TOLERANCES
0.5-6 = ±0.2
6-30 = ±0.4
30-120 = ±0.6
120-315 = ±1
315-1000 = ±1.6
1000-2000 = ±2.4

PART NO.	
APPROVED	DATE
CHECKED	DATE
DRAWN	DATE

Mark C
Mark C
Betty

09-08-99'
09-08-99'
09-08-99'

Amphenol - Kai Jack	
TAINAN TAIWAN	
TITLE	
MCX P.C. BOARD RECEPT. JACK	
DRAWING NO.	
KJ-MCX6251B1-3GT30G-50	
FILE NO. F:\DWG\MCX\6251B1\50\3GT30G	

NO.	DESCRIPTION	MATERIAL	FINISH	Q'TY	DRAWING NO.
3	CONTACT PIN		NOTE 3	NOTE 4	1 MCX6251B1-3-B
2	INSULATOR		NOTE 5	NATURAL	1 MXC6251B1-2T-50
1	BODY		NOTE 1	NOTE 2	1 MCX6251B1-1

SCALE	6/1	ISSUE	B
-------	-----	-------	---

1 2 3 4 5 6 7 8 MCX Bar 91