

1 2 3 4 5 6 7 8

REVISIONS		
ISS	ZONE	DESCRIPTION\PER REQUEST\DATE

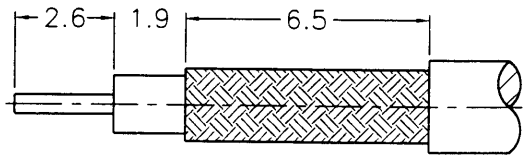

業務部

RECOMMENDED  
CABLE STRIPPING DIM'S  
(建議剝線尺寸)

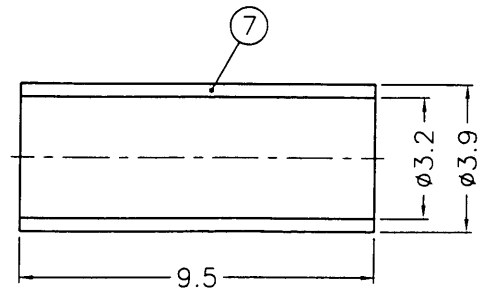
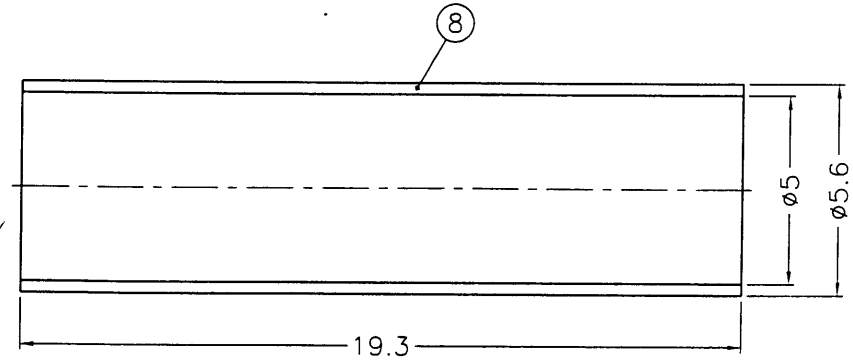
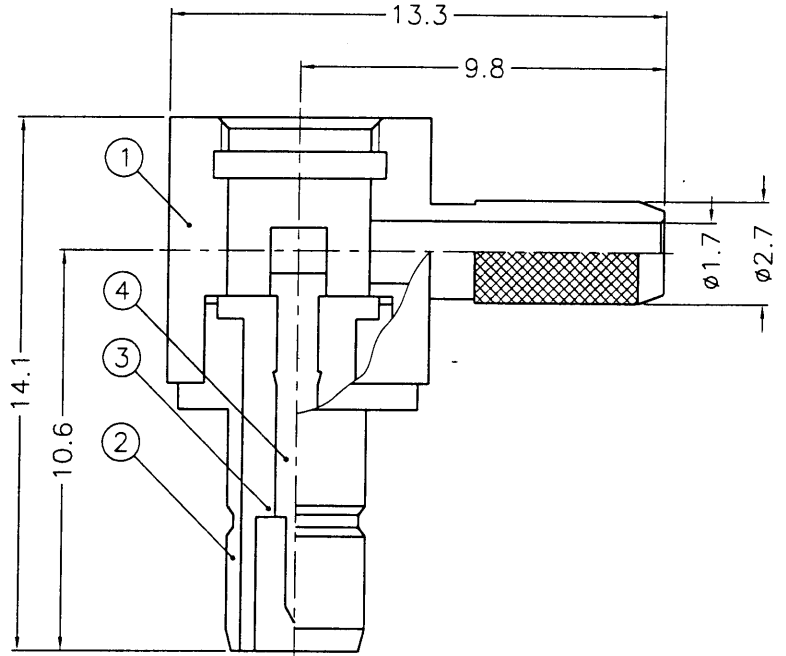
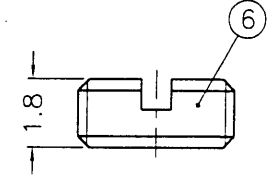
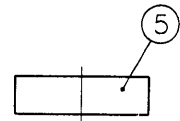

NOTES: FINISH (PLATING THICKNESS IN MICRO-INCHES)  
 1. BRASS PER QQ-B-626  
 2. GOLD PL. 3 MIN. THICK OVER NICKEL PL. 100 MIN. THICK OVER COPPER STRIKE  
 3. GOLD PL. 30 MIN. THICK OVER NICKEL PL. 100 MIN. THICK OVER COPPER STRIKE  
 4. TEFLON MIL-P-19468  
 5. JIS H 3250, C 2700

5.18  
R & D

8	HEAT SHRINK TUBING			1	HT-56/5X193
7	FERRULE	NOTE 5	NOTE 2	1	FR-39/32X95
6	COVER	NOTE 1	NOTE 2	1	SMA1112A3-8-B
5	INSULATOR	PE	NATURAL	1	SMB5090-7
4	CONTACT PIN	NOTE 1	NOTE 3	1	SMB1112A1-4
3	INSULATOR	NOTE 4	NATURAL	1	SMB1112A1-3T-50
2	BODY	NOTE 1	NOTE 2	1	SMB1112A1-2
1	BARREL	NOTE 1	NOTE 2	1	SMB5090-3-27/17-A

DIMENSIONS ARE IN MILLIMETERS  
 UNLESS OTHERWISE SPECIFIED TOLERANCES  
 0.5-6 = ±0.2  
 6-30 = ±0.4  
 30-120 = ±0.6  
 120-315 = ±1  
 315-1000 = ±1.6  
 1000-2000 = ±2.4

PART NO.	
APPROVED	DATE 05-14-99'
CHECKED	DATE 05-14-99'
DRAWN	DATE 05-14-99'

**KAI JACK INDUSTRIAL CO., LTD.**  
TAINAN TAIWAN R.O.C.

TITLE: SMB R/A CRIMP JACK (FOR RG-174/U, 188A/U, 316/U)  
 DRAWING NO.: KJ-SMB1112A1-3GT30G-316U-50  
 FILE NO.: F:\DWG\SMB\1112A1\316U-50\3GT30G

NO.	DESCRIPTION	MATERIAL	FINISH	Q'TY	DRAWING NO.	SCALE	5/1	ISSUE	A

5/18/99