

1 2 3 4 5 6 7 8

REVISIONS		
ISS	ZONE	DESCRIPTION\PER REQUEST\DATE

業務部

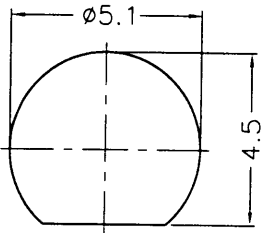

RECOMMENDED MOUNTING HOLE

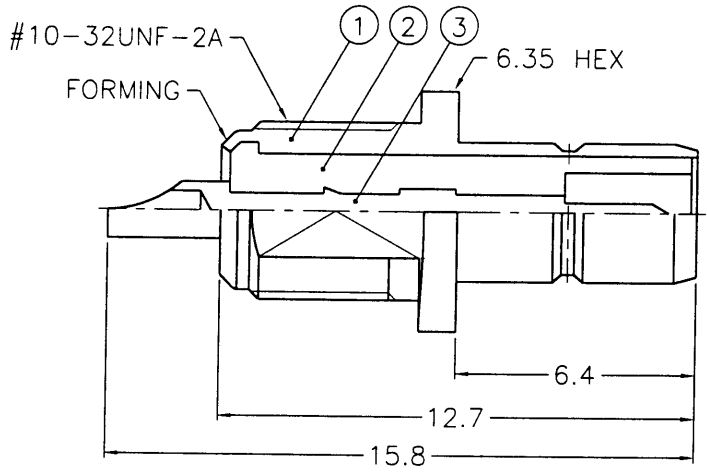
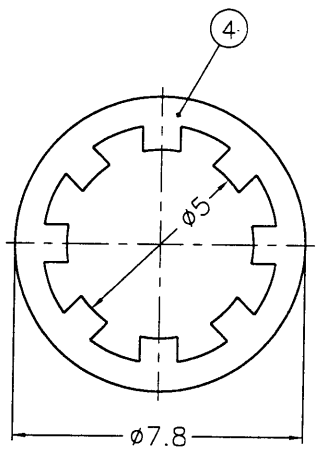
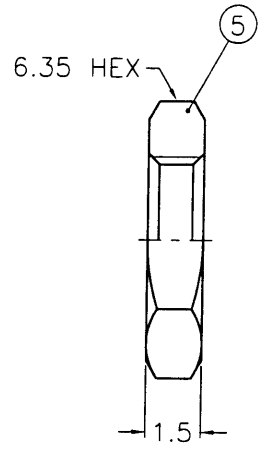

NOTES: FINISH (PLATING THICKNESS IN MICRO-INCHES)
 1. BRASS PER QQ-B-626
 2. BRASS PER QQ-B-613
 3. GOLD PL. 3 MIN. THICK OVER NICKEL PL. 100 MIN. THICK OVER COPPER STRIKE
 4. GOLD PL. 30 MIN. THICK OVER NICKEL PL. 100 MIN. THICK OVER COPPER STRIKE
 5. TEFLON MIL-P-19468

88.5.05

NO.	DESCRIPTION	MATERIAL	FINISH	Q'TY	DRAWING NO.
5	HEX NUT	NOTE 1	NOTE 3	1	HN635-10-32X15
4	LOCK WASHER	NOTE 2	NOTE 3	1	LW-78/5X05
3	CONTACT PIN	NOTE 1	NOTE 4	1	SMB7430-3-A
2	INSULATOR	NOTE 5	NATURAL	1	SMB7310-2T-50-A
1	BODY	NOTE 1	NOTE 3	1	SMB7310-1-A

DIMENSIONS ARE IN MILLIMETERS
 UNLESS OTHERWISE SPECIFIED TOLERANCES
 0.5-6 = ±0.2
 6-30 = ±0.4
 30-120 = ±0.6
 120-315 = ±1
 315-1000 = ±1.6
 1000-2000 = ±2.4

PART NO.	DATE
APPROVED <i>Mark C</i>	05-04-99'
CHECKED <i>Mark C</i>	05-04-99'
DRAWN <i>Betty L</i>	05-04-99'

KAI JACK INDUSTRIAL CO., LTD.
 TAINAN TAIWAN R.O.C.

TITLE: SMB BULKHEAD RECEPT. JACK

DRAWING NO. KJ-SMB1351B1-3GT30G-50

FILE NO. F:\DWG\SMB\1351B1\50\3GT30G

F
E
D
C
B
A

F
E
D
C
B
A

1 2 3 4 5 6 7 8

SMB2017