

REVISIONS		
ISS	ZONE	DESCRIPTION\PER REQUEST\DATE

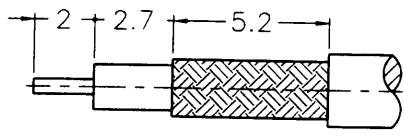

業務部

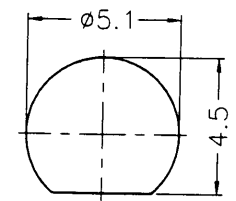

RECOMMENDED
CABLE STRIPPING DIM'S
(建議剝線尺寸)

RECOMMENDED
MOUNTING HOLE
(建議架設孔)

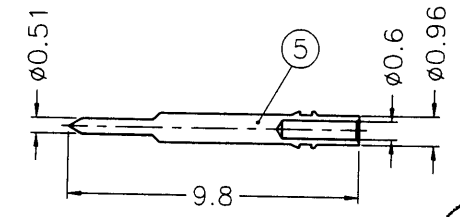
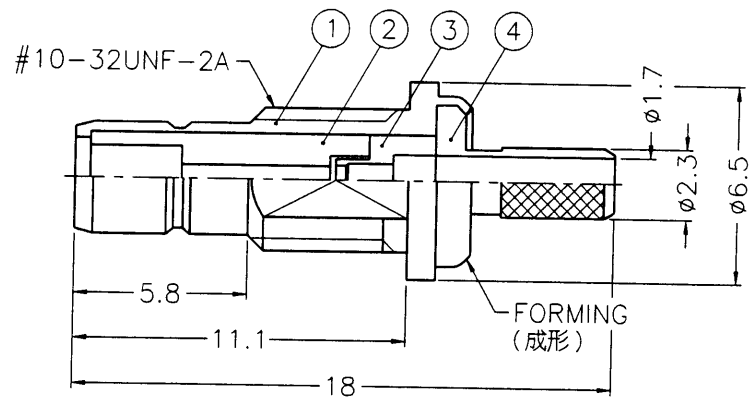
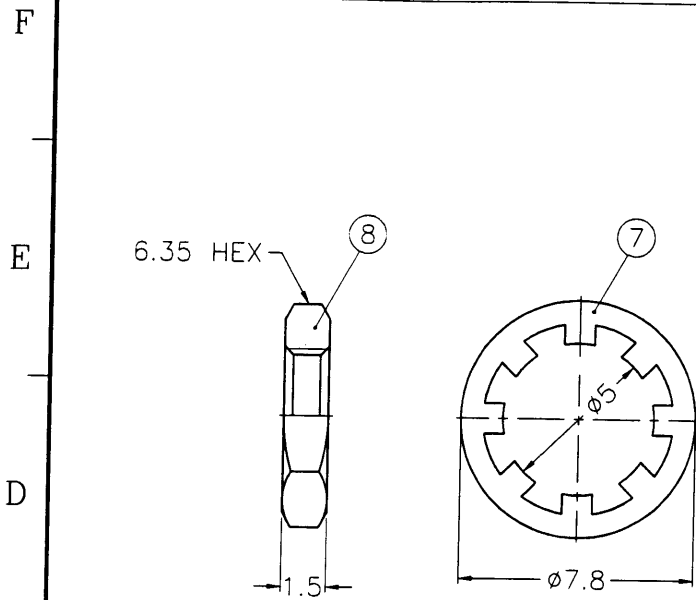

1. CRIMPED FERRULE
HEX CRIMP SIZE .128"
2. CRIMPED CONTACT PIN
SQ. CRIMP SIZE 0.7(mm)

89.1.24
R.S.

NOTES: FINISH (PLATING THICKNESS IN MICRO-INCHES)
 1. BRASS PER QQ-B-626
 2. BRASS PER QQ-B-613
 3. GOLD PL. 3 MIN. THICK OVER NICKEL PL. 100 MIN. THICK OVER COPPER STRIKE
 4. GOLD PL. 30 MIN. THICK OVER NICKEL PL. 100 MIN. THICK OVER COPPER STRIKE
 5. TEFLON MIL-P-19468

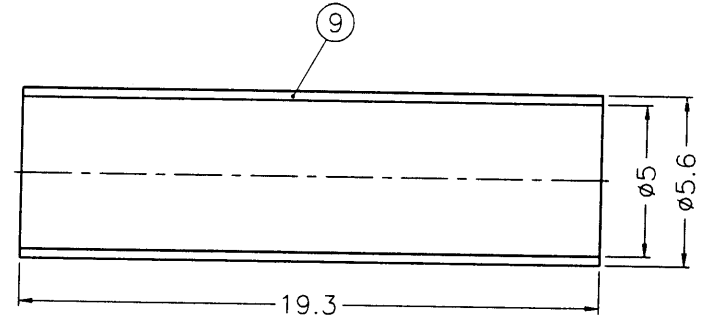
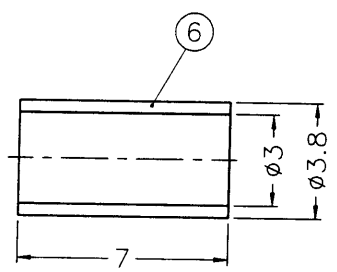

NO.	DESCRIPTION	MATERIAL	FINISH	Q'TY	DRAWING NO.
9	HEAT SHRINK TUBING			1	HT-56/5X193
8	HEX NUT	NOTE 1	NOTE 3	1	HN635-10-32X15
7	LOCK WASHER	NOTE 2	NOTE 3	1	LW-78/5X05
6	FERRULE	COPPER	NOTE 3	1	FR-38/3X7C
5	CONTACT PIN	NOTE 1	NOTE 4	1	SMB1421A1-5-096/06
4	BARREL	NOTE 1	NOTE 3	1	SMB6121A1-4-23/17-C
3	INSULATOR	NOTE 5	NATURAL	1	SMB6121B2-3T-50
2	INSULATOR	NOTE 5	NATURAL	1	SMB1421A1-2T-50
1	BODY	NOTE 1	NOTE 3	1	SMB1421A1-1-B

DIMENSIONS ARE IN MILLIMETERS		PART NO.
UNLESS OTHERWISE SPECIFIED TOLERANCES		APPROVED <i>A. Cook</i> DATE 01-19-00'
0.5-6 = ±0.2		CHECKED <i>Coole. W</i> DATE 01-19-00'
6-30 = ±0.4		DRAWN <i>Abel</i> DATE 01-19-00'
30-120 = ±0.6		
120-315 = ±1		
315-1000 = ±1.6		
1000-2000 = ±2.4		

Amphenol - Kai Jack
TAINAN TAIWAN

TITLE: SMB BULKHEAD CRIMP JACK (FOR RG-174/U, 188A/U, 316/U)

DRAWING NO.: KJ-SMB1421A1-3GT30G-316U-50

FILE NO.: F:\DWG\SMB\1421A1\316U-50\3GT30G