

REVISIONS		
ISS	ZONE	DESCRIPTION\PER REQUEST\DATE

業務部

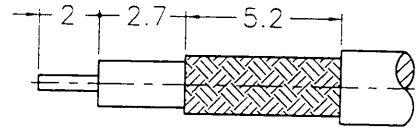

RECOMMENDED
CABLE STRIPPING DIM'S
(建議剝線尺寸)

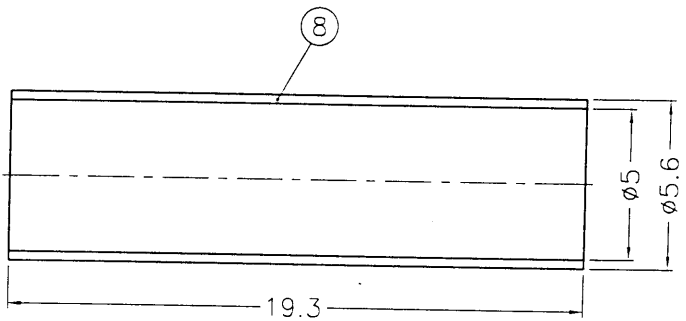
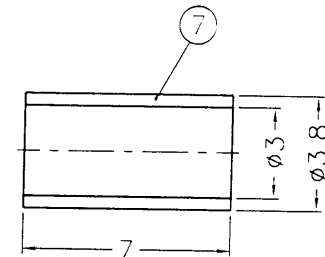
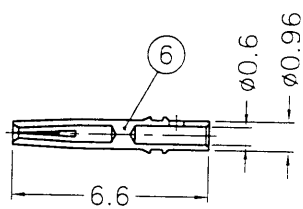
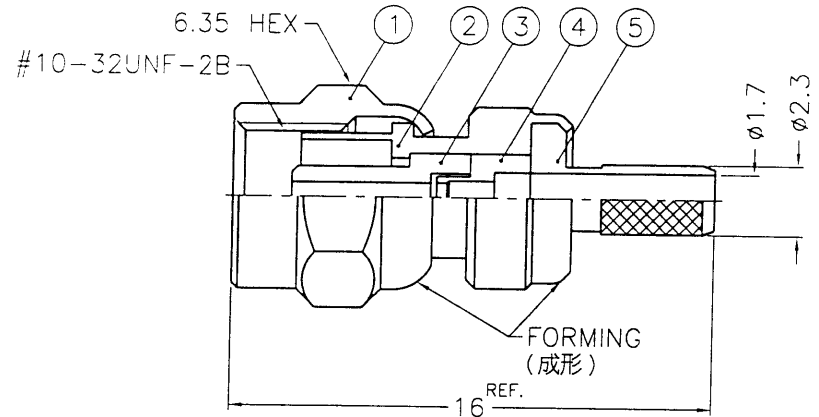

88.9.14
R&D

- NOTES: FINISH (PLATING THICKNESS IN MICRO-INCHES)
- BRASS PER QQ-B-626
 - GOLD PL. 3 MIN. THICK OVER NICKEL PL. 100 MIN. THICK OVER COPPER STRIKE
 - BERYLLIUM COPPER PER QQ-C-530
 - GOLD PL. 30 MIN. THICK OVER NICKEL PL. 100 MIN. THICK OVER COPPER STRIKE
 - TEFLON MIL-P-19468

1. CRIMPED FERRULE
HEX CRIMP SIZE .128"

8	HEAT SHRINK TUBING			1	HT-56/SX193
7	FERRULE	COPPER	NOTE 2	1	FR-38/3X7C
6	CONTACT PIN	NOTE 3	NOTE 4	1	SMB6121B2-5-096/06-D
5	BARREL	NOTE 1	NOTE 2	1	SMB6121A1-4-23/17-C
4	INSULATOR	NOTE 5	NATURAL	1	SMB6121B2-3T-50
3	INSULATOR	NOTE 5	NATURAL	1	SMB6121A1-2T-50
2	BODY	NOTE 1	NOTE 2	1	SMC6121A1-2-B
1	SHELL	NOTE 1	NOTE 2	1	SMC6121A1-1
NO.	DESCRIPTION	MATERIAL	FINISH	Q'TY	DRAWING NO.

DIMENSIONS ARE IN MILLIMETERS
UNLESS OTHERWISE SPECIFIED TOLERANCES

0.5-6	= ±0.2
6-30	= ±0.4
30-120	= ±0.6
120-315	= ±1
315-1000	= ±1.6
1000-2000	= ±2.4

PART NO.	
APPROVED	DATE 09-09-99
CHECKED	DATE 09-09-99
DRAWN	DATE 09-09-99

Amphenol - Kai Jack	
TAINAN TAIWAN	
TITLE	SMC CRIMP PLUG (RG-174/U,188A/U,316/U)
DRAWING NO.	KJ-SMC6121A1-3GT30G-316U-50
FILE NO.	F:\DWG\SMC\6121A1\316U-50\3GT30G

A