

ISS	ZONE	REVISIONS		DESCRIPTION\PER REQUEST\DATE

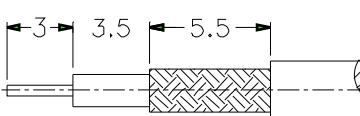

RECOMMENDED
CABLE STRIPPING DIM'S

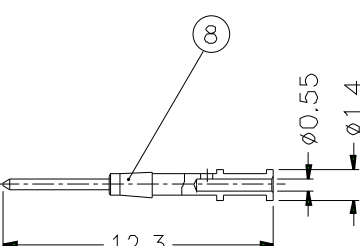

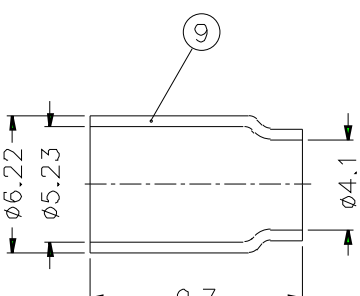

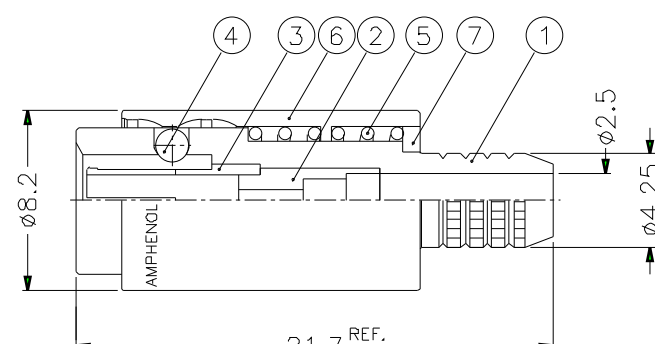

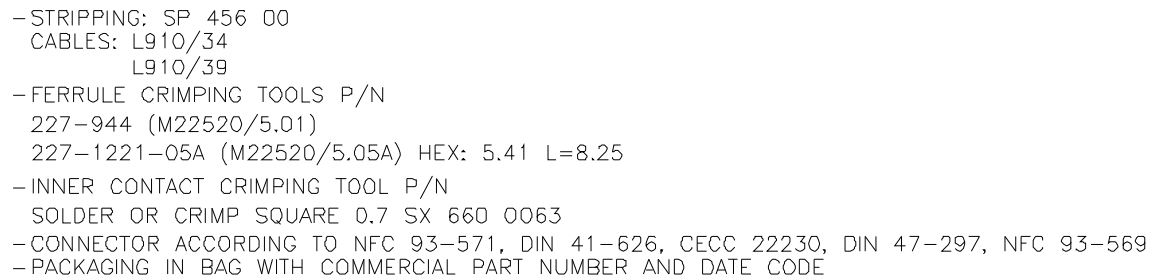

- STRIPPING: SP 456 00
CABLES: L910/34
L910/39
- FERRULE CRIMPING TOOLS P/N
227-944 (M22520/5.01)
227-1221-05A (M22520/5.05A) HEX: 5.41 L=8.25
- INNER CONTACT CRIMPING TOOL P/N
SOLDER OR CRIMP SQUARE 0.7 SX 660 0063
- CONNECTOR ACCORDING TO NFC 93-571, DIN 41-626, CECC 22230, DIN 47-297, NFC 93-569
- PACKAGING IN BAG WITH COMMERCIAL PART NUMBER AND DATE CODE

NO.	DESCRIPTION	MATERIAL	FINISH	Q'TY	DRAWING NO.	SCALE	3/1	ISSUE	A	FILE NO.
9	FERRULE	COPPER	NICKEL	1						
8	CONTACT PIN	BRASS	GOLD	1						
7	RING	BRASS	NICKEL	1						
6	OUTER BODY	BRASS	NICKEL	1						
5	SPRING	STAINLESS STEEL	NATURAL	2						
4	BALL	STAINLESS STEEL	NATURAL	3						
3	OUTER CONTACT	BECU	GOLD	1						
2	INSULATOR	TEFLON	NATURAL	1						
1	BODY	BRASS	NICKEL	1						

DIMENSIONS ARE IN MILLIMETERS				PART NO. 102 799 34		<h1>Amphenol</h1>	
UNLESS OTHERWISE SPECIFIED TOLERANCES 0.5-6 = ±0.2 6-30 = ±0.4 30-120 = ±0.6 120-315 = ±1 315-1000 = ±1.6 1000-2000 = ±2.4				APPROVED	DATE		TITLE
					10-11-01'		1.0/2.3 CRIMP PLUG
				CHECKED	DATE		DRAWING NO.
					10-11-01'		
				DRAWN	DATE	ITEM NO.	
					10-11-01'		