

1 2 3 4 5 6 7 8

REVISIONS		
ISS	ZONE	DESCRIPTION\PER REQUEST\DATE

業務部

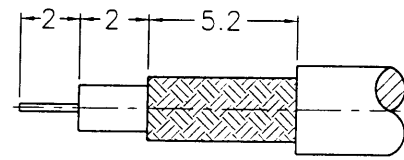

RECOMMENDED
CABLE STRIPPING DIM'S
(建議剝線尺寸)

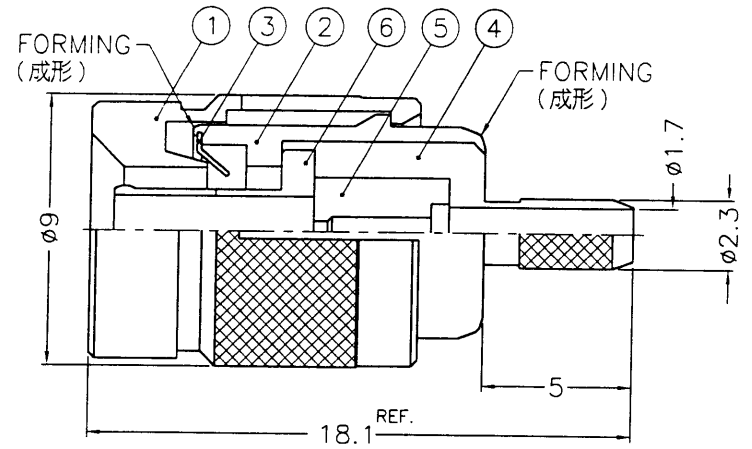
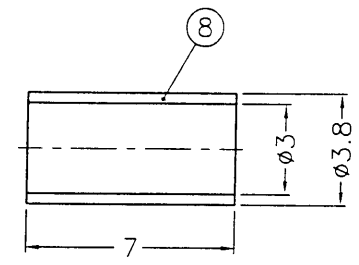
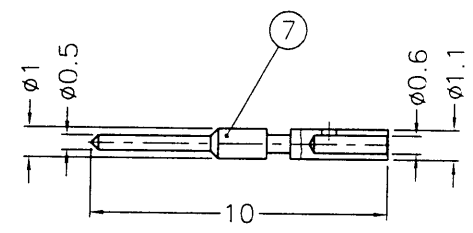

- NOTES: FINISH (PLATING THICKNESS IN MICRO-INCHES)
- BRASS PER QQ-B-626
 - PHOSPHOR BRONZE PER QQ-B-750
 - BERYLLIUM COPPER PER QQ-C-530
 - NICKEL PL. 100 MIN. THICK OVER COPPER STRIKE
 - GOLD PL. 3 MIN. THICK OVER NICKEL PL. 100 MIN. THICK OVER COPPER STRIKE
 - GOLD PL. 30 MIN. THICK OVER NICKEL PL. 100 MIN. THICK OVER COPPER STRIKE
 - TEFLON MIL-P-19468

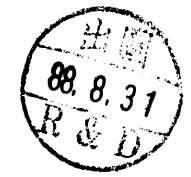

NO.	DESCRIPTION	MATERIAL	FINISH	Q'TY	DRAWING NO.
8	FERRULE	COPPER	NOTE 4	1	FR-38/3X7C
7	CONTACT PIN	NOTE 1	NOTE 6	1	1231121A1-7-11/06
6	OUT CONTACT	NOTE 2	NOTE 5	1	1231121A1-6-B
5	INSULATOR	NOTE 7	NATURAL	1	1231121A1-5T-316U
4	BARREL	NOTE 1	NOTE 4	1	1231121A1-4-23/17
3	SPRING	NOTE 3	NATURAL	1	123-PLUG-SPR
2	BODY	NOTE 1	NOTE 4	1	1231121A1-2-B
1	SHEEL	NOTE 1	NOTE 4	1	1231121A1-1-B

DIMENSIONS ARE IN MILLIMETERS
UNLESS OTHERWISE SPECIFIED TOLERANCES

0.5-6 = ±0.2
6-30 = ±0.4
30-120 = ±0.6
120-315 = ±1
315-1000 = ±1.6
1000-2000 = ±2.4

PART NO.	APPROVED	DATE
	<i>Mark C</i>	08-30-99
CHECKED	<i>Mark C</i>	DATE
		08-30-99
DRAWN	<i>Ada</i>	DATE
		08-30-99

KAI JACK INDUSTRIAL CO., LTD.
TAINAN TAIWAN R.O.C.

TITLE: 1.0/2.3 CRIMP PLUG (FOR RG-174/U,188A/U,316/U)

DRAWING NO. KJ-1231121A1-N/3GT30G-316U-50

FILE NO. F:\DWG\123\1121A1\316U-50\N3GT30G

F
E
D
C
B
A

F
E
I
C
E
A

8720066