

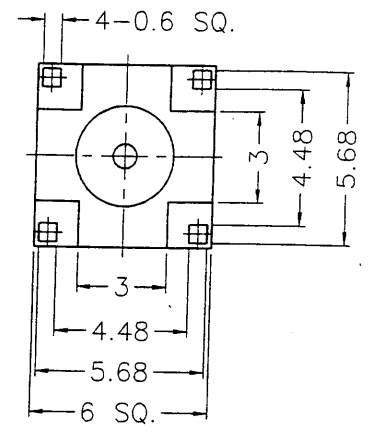

ISS		ZONE		REVISIONS	
				DESCRIPTION\PER REQUEST\DATE	

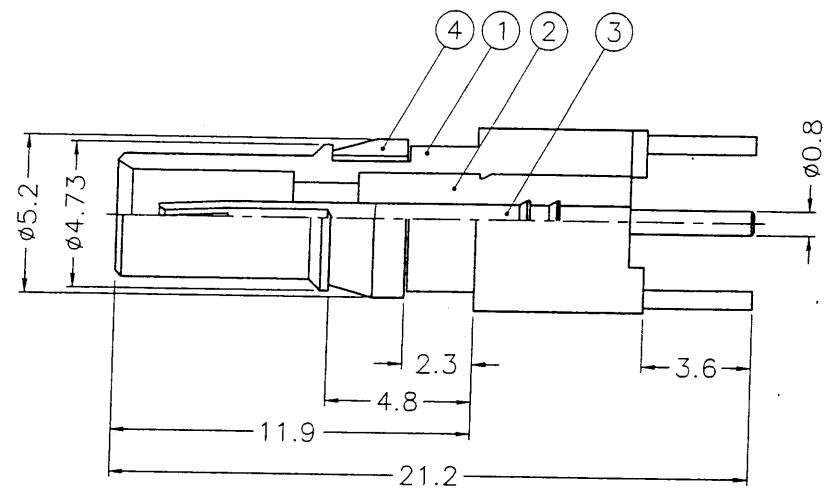
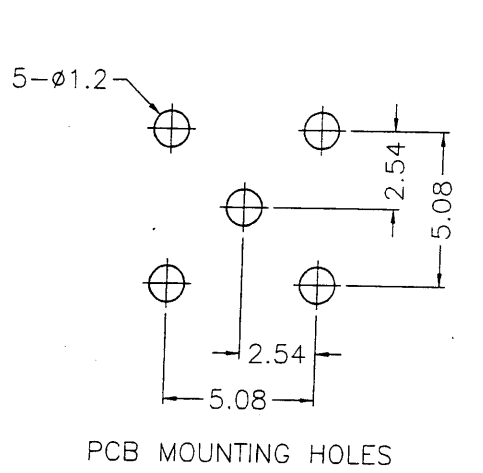

NOTES: FINISH (PLATING THICKNESS IN MICRO-INCHES)

- BRASS PER QQ-B-626
- BERYLLIUM COPPER PER QQ-C-530
- NICKEL PL. 100 MIN. THICK OVER COPPER STRIKE
- GOLD PL. 3 MIN. THICK OVER NICKEL PL. 100 MIN. THICK OVER COPPER STRIKE
- GOLD PL. 30 MIN. THICK OVER NICKEL PL. 100 MIN. THICK OVER COPPER STRIKE
- TEFLON MIL-P-19468



DIMENSIONS ARE IN MILLIMETERS				PART NO.		 KAI JACK INDUSTRIAL CO., LTD. TAINAN TAIWAN R.O.C.
UNLESS OTHERWISE SPECIFIED TOLERANCES				APPROVED		
0.5-6 = \pm 0.2				DATE		1.0/2.3 PCB JACK
6-30 = \pm 0.4				CHECKED		DRAWING NO.
30-120 = \pm 0.6				DATE		KJ-1236251L2-N/3GT30G-50
120-315 = \pm 1				DRAWN		FILE NO. F:\DWG\123\6251L2\50\N3GT30G
315-1000 = \pm 1.6				DATE		
1000-2000 = \pm 2.4				DATE		

NO.	DESCRIPTION	MATERIAL	FINISH	Q'TY	DRAWING NO.
4	RETAINER RING	NOTE 1	NOTE 3	1	SZ1111C1-5-B
3	CONTACT PIN	NOTE 2	NOTE 5	1	1236251L1-3
2	INSULATOR	NOTE 6	NATURAL	1	1236251L2-2T-50
1	BODY	NOTE 1	NOTE 4	1	1236251L2-1

F

E

D

C

B

A

1

2

3

4

5

6

7

8