

ISS	ZONE	DESCRIPTION \ PER REQUEST \ DATE
-----	------	----------------------------------

F

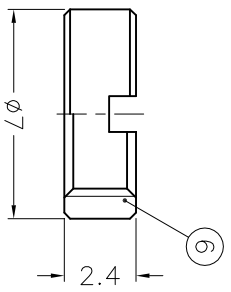

1 2 3 4 5 6 7 8

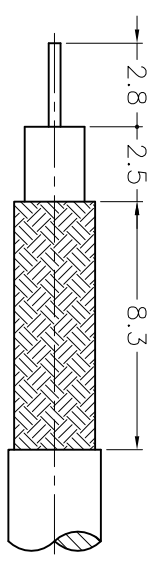

RECOMMENDED
CABLE STRIPPING DIM'S
(« OA3-e½u?0?o

F

D

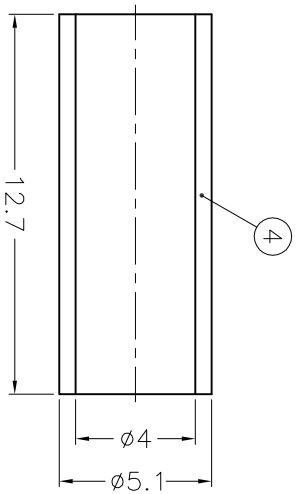
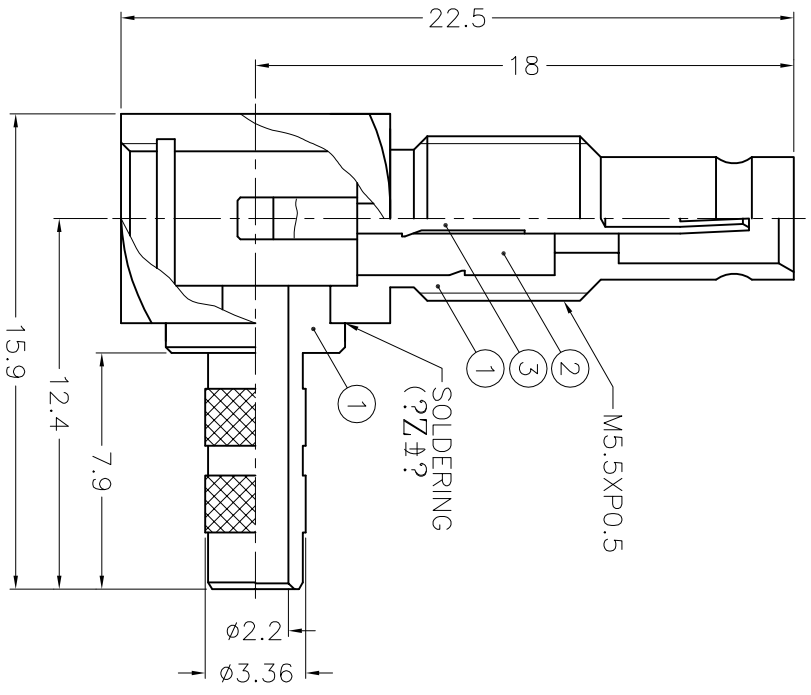

D

C

- NOTES: FINISH (PLATING THICKNESS IN MICRO-INCHES)
1. BRASS PER QQ-B-626
 2. BERYLLIUM COPPER PER QQ-C-530
 3. NICKEL PL. 100 MIN. THICK OVER COPPER STRIKE
 4. GOLD PL. 3 MIN. THICK OVER NICKEL PL. 100 MIN. THICK OVER COPPER STRIKE
 5. GOLD PL. 30 MIN. THICK OVER NICKEL PL. 100 MIN. THICK OVER COPPER STRIKE
 6. TEFLON MIL-P-19468
 7. JIS H 3250, C 2700

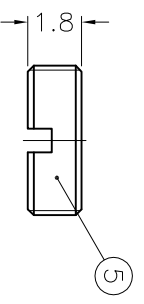

B

6	NO.	DESCRIPTION	MATERIAL	FINISH	Q'TY	DRAWING NO.	SCALE	4/1	ISSUE	1
5	COVER	NOTE 1	NOTE 3	NOTE 1	NOTE 3	1	123-JACK-SN			
4	FERRULE	NOTE 7	NOTE 3	NOTE 1	NOTE 3	1	FR-51/4X127			
3	CONTACT PIN	NOTE 2	NOTE 5	NOTE 1	NOTE 5	1	1236412A2-3-75			
2	INSULATOR	NOTE 6	NATURAL	NOTE 1	NOTE 6	1	1236412A2-2T-75			
1	HOUSING WITH BARREL	NOTE 1	NOTE 4	NOTE 1	NOTE 4	1	1236412A2-1S-336/22-75			

A

DIMENSIONS ARE IN MILLIMETERS
UNLESS OTHERWISE SPECIFIED
TOLERANCES

- 0.5-6 = ±0.2
- 6-30 = ±0.4
- 30-120 = ±0.6
- 120-315 = ±1
- 315-1000 = ±1.6
- 1000-2000 = ±2.4

PART NO.

APPROVED DATE 04-17-00'

CHECKED DATE 04-17-00'

Amphenol - Kai Jack
TAINAN TAIWAN

TITLE
1.0/2.3 R/A CRIMP JACK

DRAWING NO.
KJ-1236412A2-N/3GT30G-ST212-75

DRAWN SHALY DATE 04-17-00'

A