

REVISIONS		
ISS	ZONE	DESCRIPTION\PER REQUEST\DATE

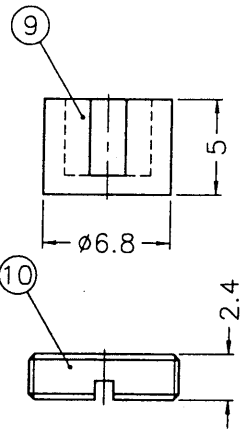
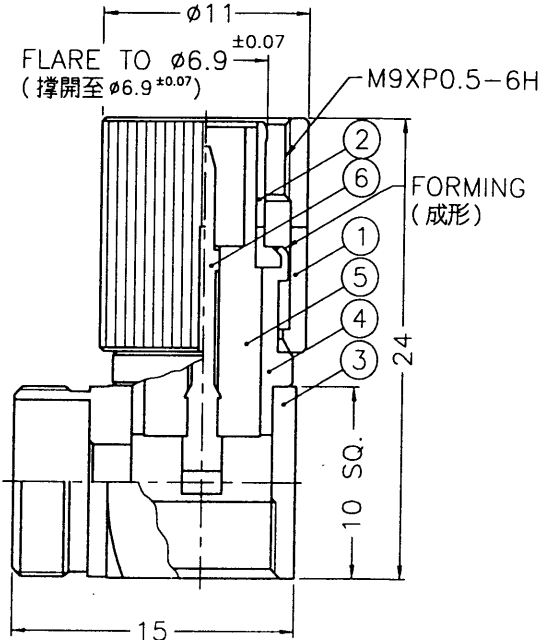
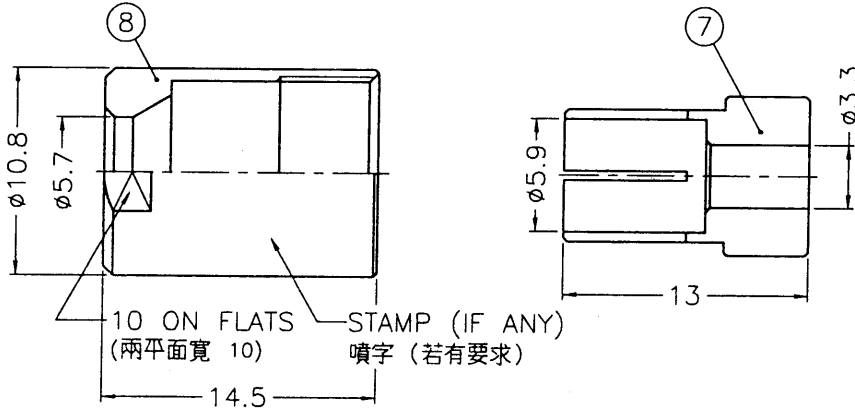
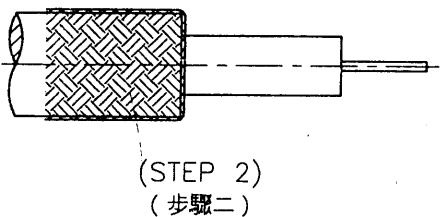
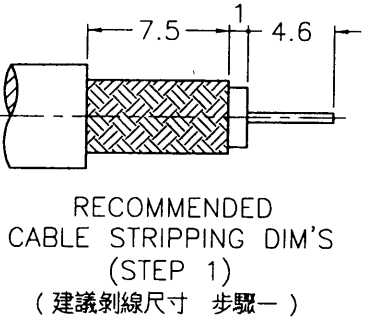

- NOTES: FINISH (PLATING THICKNESS IN MICRO-INCHES)
- BRASS PER QQ-B-626
 - NICKEL PL. 100 MIN. THICK OVER COPPER STRIKE
 - PHOSPHOR BRONZE PER QQ-B-750
 - GOLD PL. 3 MIN. THICK OVER NICKEL PL. 100 MIN. THICK OVER COPPER STRIKE
 - TEFLON MIL-P-19468

1. CONTACT PIN TO SOLDER

10	NUT	NOTE 1	NOTE 2	1	15687061606-5
9	INSULATOR	DELRIN	NATURAL	1	15687061606-4
8	NUT	NOTE 1	NOTE 2	1	1566442A1-7-57
7	BRAID CLAMP	NOTE 1	NOTE 2	1	1566442A1-6-59 /33
6	CONTACT PIN	NOTE 1	NOTE 4	1	1561112A1-6-B
5	INSULATOR	NOTE 5	NATURAL	1	NS16AAH01A
4	BODY	NOTE 1	NOTE 2	1	1561112A1-4
3	HOUSING	NOTE 1	NOTE 2	1	1566442A1-2-39
2	OUT CONTACT	NOTE 3	NOTE 4	1	1561121G1-2
1	SHELL	NOTE 1	NOTE 2	1	1561121G1-1-B
NO.	DESCRIPTION	MATERIAL	FINISH	Q'TY	DRAWING NO.

DIMENSIONS ARE IN MILLIMETERS				PART NO.	
UNLESS OTHERWISE SPECIFIED TOLERANCES				APPROVED	DATE
0.5-6	= ±0.2	6-30	= ±0.4	<i>Andy.C</i>	07-23-03'
30-120	= ±0.6	120-315	= ±1	<i>Andy.C</i>	07-23-03'
315-1000	= ±1.6	1000-2000	= ±2.4	JOYCE	07-23-03'
SCALE	2.5/1	ISSUE	A1	FILE NO.	F:\DWG\156\1142A2\3C2V-75\N3GT3G

Amphenol	
Danbury, CT, USA - Tainan, Taiwan - Shenzhen, China	
TITLE	1.6/5.6 R/A CLAMP PLUG (FOR PACIFIC 3C-2V CABLE)
DRAWING NO.	1561142A2-N/3GT3G-3C2V-75
ITEM NO.	