

REVISIONS		
ISS	ZONE	DESCRIPTION\PER REQUEST\DATE

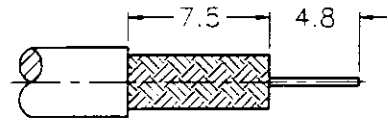

RECOMMENDED  
CABLE STRIPPING DIM'S  
(STEP 1)  
(建議剝線尺寸 步驟一)

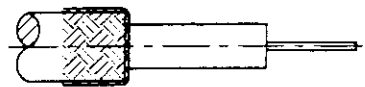

(STEP 2)  
(步驟二)

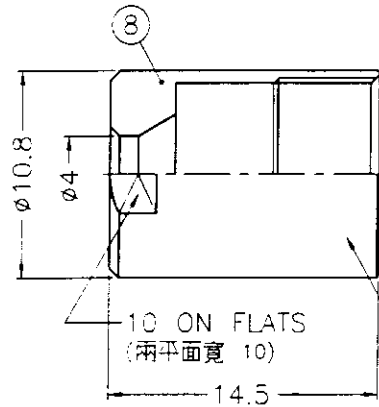

STAMP (IF ANY)  
噴字 (若有要求)

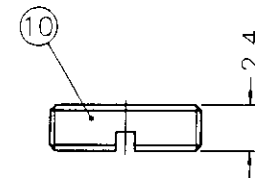
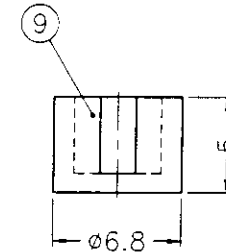
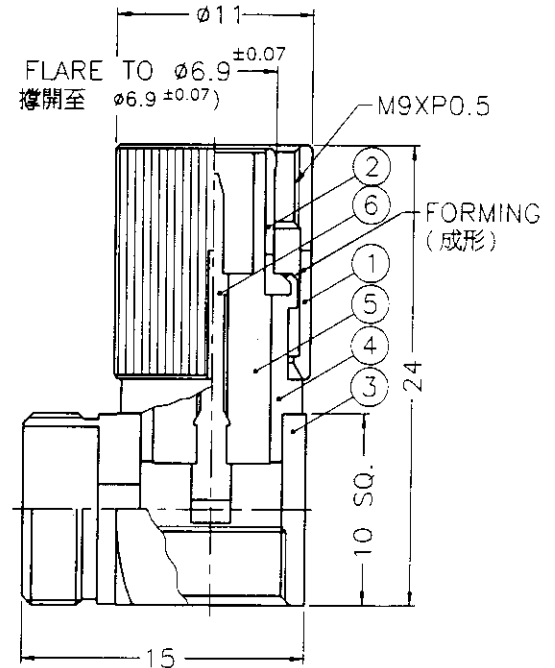
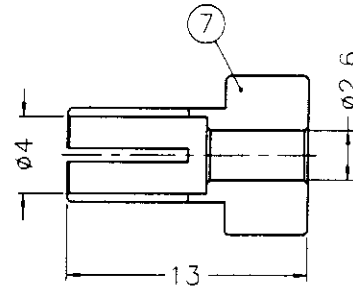

NOTES: FINISH (PLATING THICKNESS IN MICRO-INCHES)

- BRASS PER QQ-B-626
- NICKEL PL. 100 MIN. THICK OVER COPPER STRIKE
- P-OSP-CR BRONZE PER QQ-B-750
- GOLD PL. 3 MIN. THICK OVER NICKEL PL. 100 MIN. THICK OVER COPPER STRIKE
- TEFLON MIL-P-19468

1. CONTACT PIN TO SOLDER

10	NUT	NOTE 1	NOTE 2	1	15687061606-5
9	INSULATOR	DEL.RIN	NATURAL	1	15687061606-4
8	NUT	NOTE 1	NOTE 2	1	1566442A1-7-4
7	BRAID CLAMP	NOTE 1	NOTE 2	1	1566442A1-6-4 /26
6	CONTACT PIN	NOTE 1	NOTE 4	1	156112A1-6-B
5	INSULATOR	NOTE 5	NATURAL	1	1561142A2-5T-75
4	BODY	NOTE 1	NOTE 2	1	156112A1-4
3	HOUSING	NOTE 1	NOTE 2	1	1566442A1-2-26
2	OUT CONTACT	NOTE 3	NOTE 4	1	1561121G1-2
1	SHELL	NOTE 1	NOTE 2	1	1561121G1-1-B

DIMENSIONS ARE IN MILLIMETERS	
UNLESS OTHERWISE SPECIFIED TOLERANCES	
0.5-6	= ±0.2
6-30	= ±0.4
30-120	= ±0.6
120-315	= ±1
315-1000	= ±1.6
1000-2000	= ±2.4

PART NO.	
APPROVED	DATE 06-26-01'
CHECKED	DATE 06-26-01'
DRAWN	DATE 06-26-01'

Amphenol - Kai Jack	
TAINAN TAIWAN	
TITLE	1.6/5.6 R/A CLAMP PLUG (FOR FLEX-3/75 CABLE)
DRAWING NO.	KJ-1561142A2-N/3GT3G-FLEX-3-75
FILE NO.	F:\DWG\156\1142A2\FLEX3-75\N3GT3G

NO.	DESCRIPTION	MATERIAL	FINISH	Q'TY	DRAWING NO.	SCALE	2.5/1	ISSUE	1
-----	-------------	----------	--------	------	-------------	-------	-------	-------	---