

REVISIONS		
ISS	ZONE	DESCRIPTION\PER REQUEST\DATE
A2	B-1	NO.8 WAS CHANGED\N/A\10-29-02'

SALES

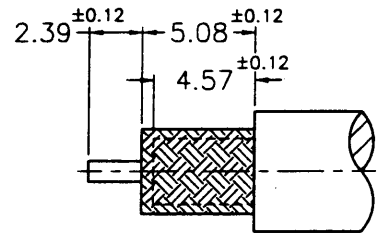

RECOMMENDED
CABLE STRIPPING DIM'S
(建議剝線尺寸)

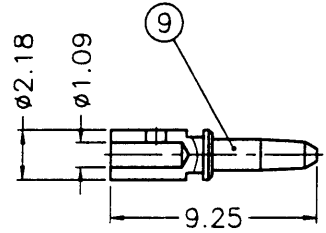
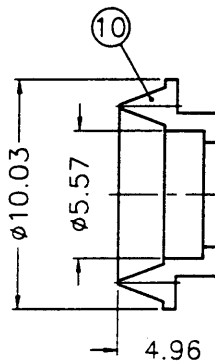
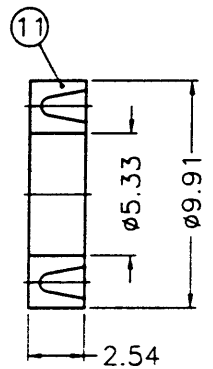
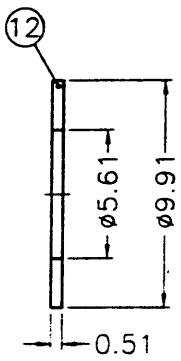

7/16-28UNEF-2B

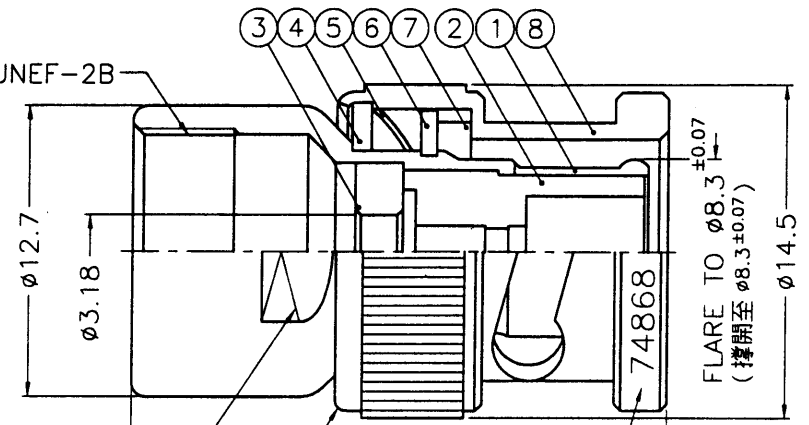

11.12 ON FLATS
(兩平面寬 11.12)

FORM OVER ALL AROUND
DO NOT BREAK THRU PLATING.
(全周成型不可破壞電鍍)

STAMP "74868 UG-88C/U"
IN 1mm HIGH DEPRESSED CHARACTERS
(戳字 "74868 UG-88C/U" 字高 1mm)

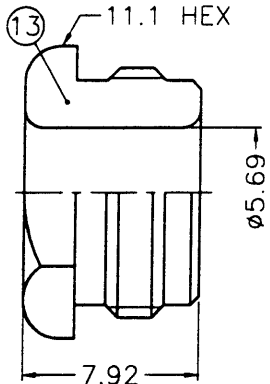

- NOTES: FINISH (PLATING THICKNESS IN MICRO-INCHES)
- BRASS PER QQ-B-626
 - BRASS PER QQ-B-613
 - NICKEL PL. 100 MIN. THICK OVER COPPER STRIKE
 - SILVER PL. 200 MIN. THICK OVER COPPER STRIKE
 - NICKEL PL. 200 MIN. THICK OVER COPPER STRIKE
 - TEFLON MIL-P-19468

13	CLAMP NUT	NOTE 1	NOTE 3	1	31-1428-1
12	WASHER	NOTE 2	NOTE 3	1	82-946-28
11	GASKET	SILICONE	RED	1	82-1536-5
10	BRAID CLAMP	NOTE 1	NOTE 3	1	82-1551-9
9	CONTACT PIN	NOTE 1	NOTE 4	1	31-2174-1
8	SHELL	NOTE 1	NOTE 3	1	31-1500-C
7	GASKET	SILICONE	RED	1	82-1535-3
6	RETAINER RING	NOTE 1	NOTE 3	1	31-10720
5	SPRING	SK5	NOTE 5	1	B50000-6
4	WASHER	NOTE 2	NOTE 3	1	WS-128/9X08
3	CLAMP BUSHING	NOTE 1	NOTE 3	1	31-2175-1
2	INSULATOR	NOTE 6	NATURAL	1	31-2173
1	BODY	NOTE 1	NOTE 3	1	31-10723
NO.	DESCRIPTION	MATERIAL	FINISH	Q'TY	DRAWING NO.

DIMENSIONS ARE IN MILLIMETERS

UNLESS OTHERWISE SPECIFIED TOLERANCES

0.5-6	= ±0.2
6-30	= ±0.4
30-120	= ±0.6
120-315	= ±1
315-1000	= ±1.6
1000-2000	= ±2.4

PART NO.	
APPROVED	DATE 10-29-02'
CHECKED	DATE 10-29-02'
DRAWN	DATE 10-29-02'
FILE NO.	F:\DWG\CNPD\31\202

Amphenol	
Danbury, CT, USA - Tainan, Taiwan - Shenzhen, China	
TITLE	BNC PLUG UG-88C/U (FOR RG-58/U, 223/U, 142/U, 141/U)
DRAWING NO.	31-202
ITEM NO.	31-202

ISSUED
2002. 10. 30
I & D