

REVISIONS		
ISS	ZONE	DESCRIPTION\PER REQUEST\DATE
A2	B-5	ADDED STAMP\N/A\11-06-02'
A3	B-5	STAMP WAS CHANGED\N/A\12-30-02'

REMARK: 1. AFTER FORM OVER, CENTER CONTACT SHALL NOT ROTATE RELATIVE TO BODY A TORQUE OF 4 IN-OZ.
 (全周成型後, 中心針與主體間須能承受 4 IN-OZ 的扭力)
 2. INSULATOR MUST WITHSTAND AN 8 LB PUSH-OUT FORCE FROM BODY.
 (絕緣體與主體間需能承受 8 LB 的推力)

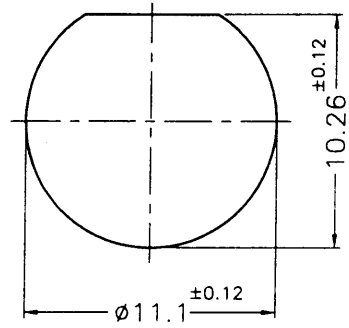

SALES

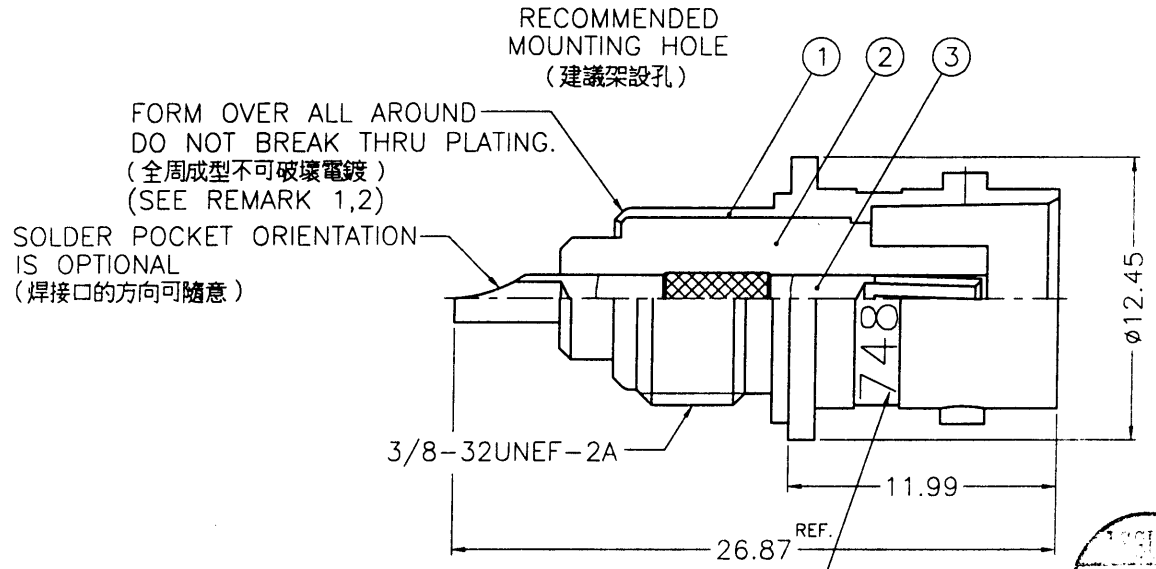
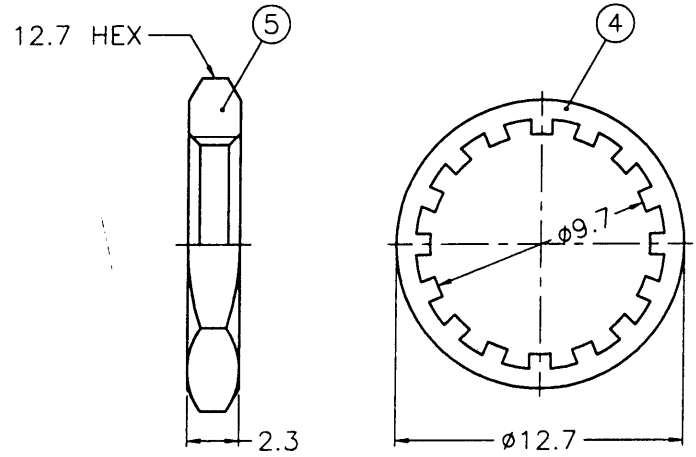

STAMP "74868 UG-625B/U" IN 1.6mm HIGH DEPRESSED CHARACTERS
 (戳字 "74868 UG-625B/U", 字高 1.6mm)

ISSUED
 2002.12.31
 R&D

- NOTES: FINISH (PLATING THICKNESS IN MICRO-INCHES)
- BRASS PER QQ-B-626
 - NICKEL PL. 100 MIN. THICK OVER COPPER STRIKE
 - BERYLLIUM COPPER PER QQ-B-530
 - SILVER PL. 200 MIN. THICK OVER COPPER STRIKE
 - TEFLON MIL-P-19468
 - PHOSPHOR BRONZE PER QQ-B-750

1. MAX. PANEL THICKNESS=3.96mm

NO.	DESCRIPTION	MATERIAL	FINISH	Q'TY	DRAWING NO.
5	HEX NUT		NOTE 1	NOTE 2	1 HN127-3/8-32X23
4	LOCK WASHER		NOTE 6	NOTE 2	1 LW-127/97X05PB
3	CONTACT PIN		NOTE 3	NOTE 4	1 31-10124
2	INSULATOR		NOTE 5	NATURAL	1 31-10125-1
1	BODY		NOTE 1	NOTE 2	1 31-1391

DIMENSIONS ARE IN MILLIMETERS				PART NO.	
UNLESS OTHERWISE SPECIFIED TOLERANCES				APPROVED	DATE
				0.5-6 = ±0.2	
				CHECKED	DATE
				6-30 = ±0.4	
				DRAWN	DATE
				30-120 = ±0.6	
				FILE NO.	
				120-315 = ±1	
				SCALE	
				315-1000 = ±1.6	
				ISSUE	
				1000-2000 = ±2.4	

Amphenol
 Danbury, CT, USA - Tainan, Taiwan - Shenzhen, China

TITLE: BNC BULKHEAD RECEPT. JACK FRONT MOUNT ASTROPLATED

DRAWING NO. 31-236

ITEM NO. 31-236

F
E
D
C
B
A

F
E
D
C
B
A