

1		2		3		4		5		6		7		8	
ISS	ZONE	DESCRIPTION \ PER REQUEST \ DATE													
A2	ALL	DESIGN WAS CHANGED \ N \ A \ 02-13-03'													

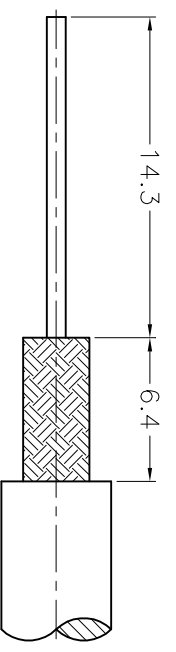

RECOMMENDED
CABLE STRIPPING DIM'S
(建議剝線尺寸)

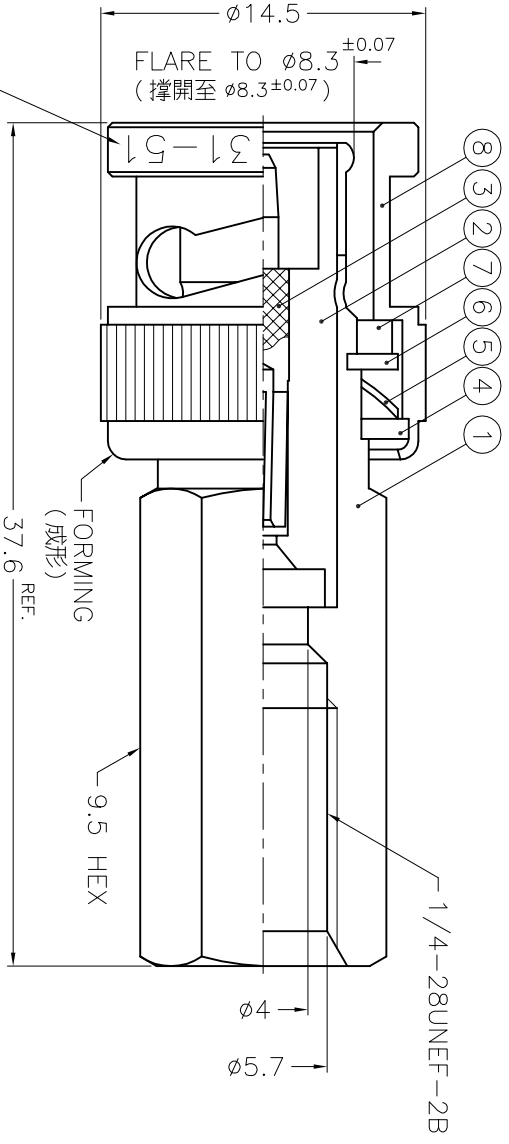

STAMP "31-5136" IN 1.2mm
HIGH DEPRESSED CHARACTERS
(數字 "31-5136" 字高 1.2mm)

- NOTES: FINISH (PLATING THICKNESS IN MICRO-INCHES)
1. BRASS PER QQ-B-626
 2. BRASS PER QQ-B-613
 3. NICKEL PL. 100 MIN. THICK OVER COPPER STRIKE
 4. NICKEL PL. 200 MIN. THICK OVER COPPER STRIKE
 5. GOLD PL. 3 MIN. THICK OVER NICKEL PL. 100 MIN. THICK OVER COPPER STRIKE
 6. TEFLON MIL-P-19468

8	7	6	5	4	3	2	1
SHELL	GASKET	RETAINER RING	SPRING	WASHER	CONTACT PIN	INSULATOR	HEX BODY
NOTE 1	RUBBER	NOTE 1	SK5	NOTE 2	NOTE 1	NOTE 6	NOTE 1
NOTE 3	RED	NOTE 3	NOTE 4	NOTE 3	NOTE 5	NATURAL	NOTE 3
1	1	1	1	1	1	1	1
B50000-1-B	GS-115/8X15	B50000-5	B50000-6	WS-128/9X08	B5100-4T-21/ 076	B5100-3T-50	B5100-2-57/4

1		2		3		4		5		6		7		8	
DIMENSIONS ARE IN MILLIMETERS		PART NO.		APPROVED		DATE		CHECKED		DATE		DRAWING NO.		ITEM NO.	
UNLESS OTHERWISE SPECIFIED TOLERANCES		DRAWN		DATE		DATE		DATE		DATE		DRAWING NO.		ITEM NO.	
0.5-6 = ±0.2		DRAWN		DATE		DATE		DATE		DATE		DRAWING NO.		ITEM NO.	
6-30 = ±0.4		CHECKED		DATE		DATE		DATE		DATE		DRAWING NO.		ITEM NO.	
30-120 = ±0.6		DATE		DATE		DATE		DATE		DATE		DRAWING NO.		ITEM NO.	
120-315 = ±1		DATE		DATE		DATE		DATE		DATE		DRAWING NO.		ITEM NO.	
315-1000 = ±1.6		DATE		DATE		DATE		DATE		DATE		DRAWING NO.		ITEM NO.	
1000-2000 = ±2.4		DATE		DATE		DATE		DATE		DATE		DRAWING NO.		ITEM NO.	
SCALE	3/1	ISSUE	A2	FILE NO.	F:\DWG\CNPD\31\5136	TITLE		DRAWING NO.		ITEM NO.		DRAWING NO.		ITEM NO.	
SCALE	3/1	ISSUE	A2	FILE NO.	F:\DWG\CNPD\31\5136	TITLE		DRAWING NO.		ITEM NO.		DRAWING NO.		ITEM NO.	

Amphenol

Danbury, CT, USA - Taichung, Taiwan - Shenzhen, China

BNC PLUG SHEET METAL CONTACT
(FOR RG-59/U & RG-62/U CABLE)

31-5136

31-5136