

REVISIONS		
ISS	ZONE	DESCRIPTION\PER REQUEST\DATE

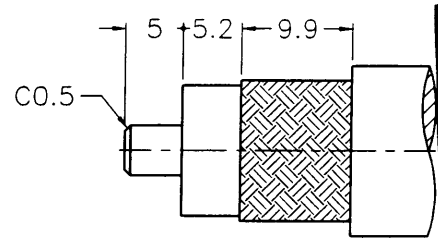

業務部

RECOMMENDED
CABLE STRIPPING DIM'S
(建議剝線尺寸)

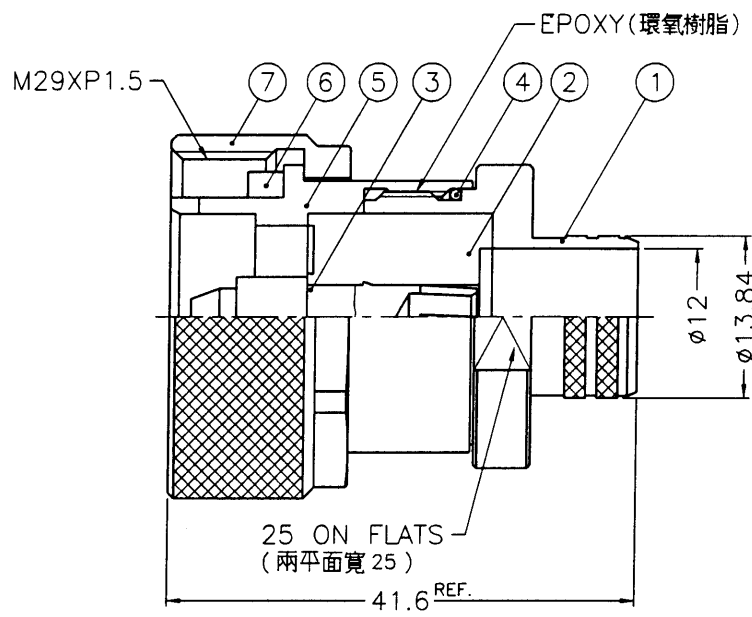
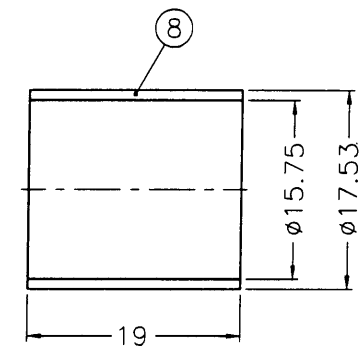

NOTES: FINISH (PLATING THICKNESS IN MICRO-INCHES)
 1. BRASS PER QQ-B-626
 2. SILVER PL. 120 MIN. THICK OVER COPPER STRIKE
 3. BERYLLIUM COPPER PER QQ-C-530
 4. SILVER PL. 200 MIN. THICK OVER COPPER STRIKE
 5. TEFLON MIL-P-19468
 6. JIS H 3250, C 2700

出圖
89.3.07
R & D

1. CRIMPED FERRULE
HEX CRIMP SIZE .6"

NO.	DESCRIPTION	MATERIAL	FINISH	Q'TY	DRAWING NO.
8	FERRULE			1	FR-1753/1575X19
7	SHELL			1	7161141A1-7
6	GASKET	SILICONE	RED	1	GS-25/205X35
5	CONTACT BODY			1	7161111A2-5
4	GASKET	SILICONE	RED	1	GS-228/20XD14
3	CONTACT PIN			1	7161111A2-3-56/46
2	INSULATOR		NATURAL	1	7161111A2-2T-L600
1	BARREL			1	7161111A2-1-1384/12

DIMENSIONS ARE IN MILLIMETERS		PART NO.	
UNLESS OTHERWISE SPECIFIED TOLERANCES		APPROVED	DATE
0.5-6 = ±0.2		<i>Asok. C</i>	03-06-00'
6-30 = ±0.4		CHECKED	DATE
30-120 = ±0.6		<i>Coal. W</i>	03-06-00'
120-315 = ±1		DRAWN	DATE
315-1000 = ±1.6		<i>Coal. W</i>	03-06-00'
1000-2000 = ±2.4			

Amphenol - Kai Jack	
TAINAN TAIWAN	
TITLE	7/16 CRIMP PLUG (FOR LMR600 CABLE)
DRAWING NO.	KJ-7161111A2-120STS-LMR600-50
FILE NO.	F:\DWG\716\1111A2\L600\120STS

F
E
D
C
B
A

1 2 3 4 5 6 7 8