

REVISIONS		
ISS	ZONE	DESCRIPTION\APPROVED\DATE
B	A-3	NO.5 WAS CHANGED\RD-DM89081901L\08-22-00'
	D-5	DRAWNING CHANGED\N/A\08-22-00'

業務部

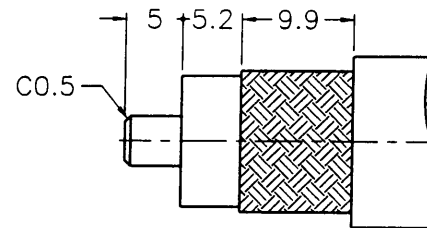

RECOMMENDED CABLE STRIPPING DIM'S
(建議剝線尺寸)

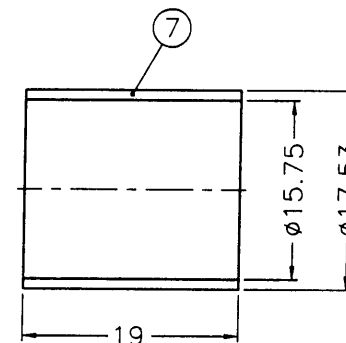
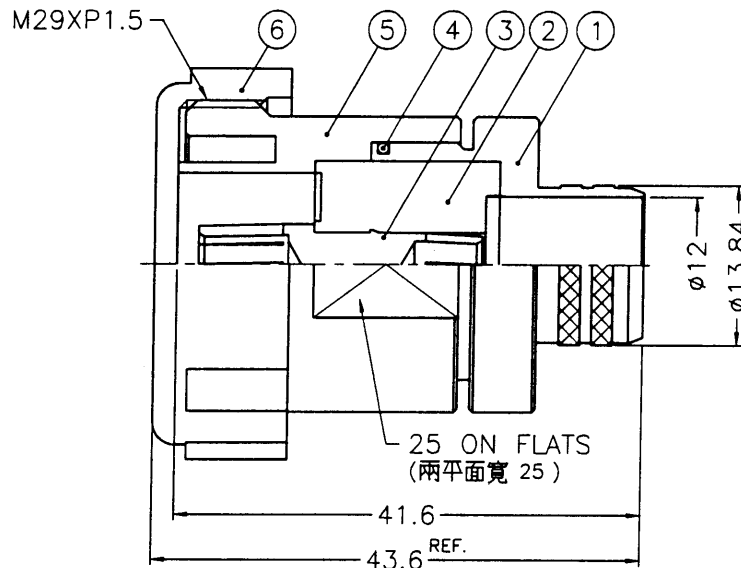

NOTES: FINISH (PLATING THICKNESS IN MICRO-INCHES)

1. BRASS PER QQ-B-626
2. SILVER PL. 120 MIN. THICK OVER COPPER STRIKE
3. BERYLLIUM COPPER PER QQ-C-530
4. SILVER PL. 200 MIN. THICK OVER COPPER STRIKE
5. TEFLON MIL-P-19468
6. BLUE, PER PANTONE 3005C
7. JIS H 3250, C 2700



1. CRIMPED FERRULE
HEX CRIMP SIZE ".6"

7	FERRULE	NOTE 7	NOTE 2	1	FR-1753/1575X19
6	COVER	PE	NOTE 6	1	7166141A1-9
5	BODY	NOTE 1	NOTE 2	1	7166111A2-5-B
4	GASKET	SILICONE	RED	1	GS-215/183XD16
3	CONTACT PIN	NOTE 3	NOTE 4	1	7166111A2-3-56/46
2	INSULATOR	NOTE 5	NATURAL	1	7161111A2-2T-L600
1	BARREL	NOTE 1	NOTE 2	1	7166111A2-1-1384/12
NO.	DESCRIPTION	MATERIAL	FINISH	Q'TY	DRAWING NO.

DIMENSIONS ARE IN MILLIMETERS
UNLESS OTHERWISE SPECIFIED TOLERANCES
0.5-6 = ±0.2
6-30 = ±0.4
30-120 = ±0.6
120-315 = ±1
315-1000 = ±1.6
1000-2000 = ±2.4

PART NO.	
APPROVED	DATE 08-22-00'
CHECKED	DATE 08-22-00'
DRAWN	DATE 08-22-00'

Amphenol - Kai Jack	
TAINAN TAIWAN	
TITLE	7/16 CRIMP JACK (FOR LMR600 CABLE)
DRAWING NO.	KJ-7166111A2-120STS-LMR600-50
FILE NO.	F:\DWG\716\6111A2\L600\120STS

F

E

D

C

B

A