

1 2 3 4 5 6 7 8

REVISIONS		
ISS	ZONE	DESCRIPTION\PER REQUEST\DATE

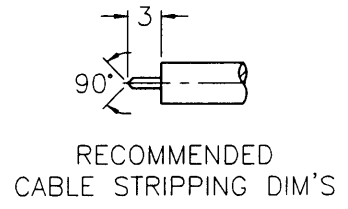
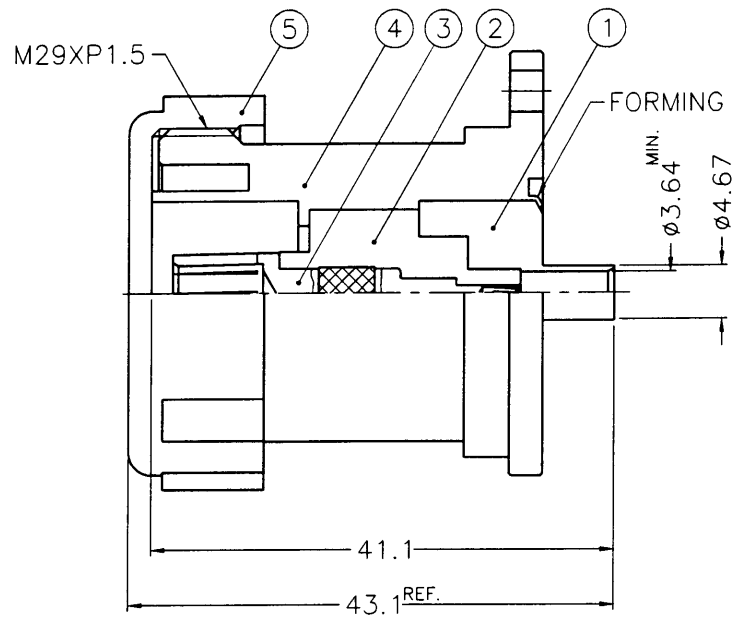
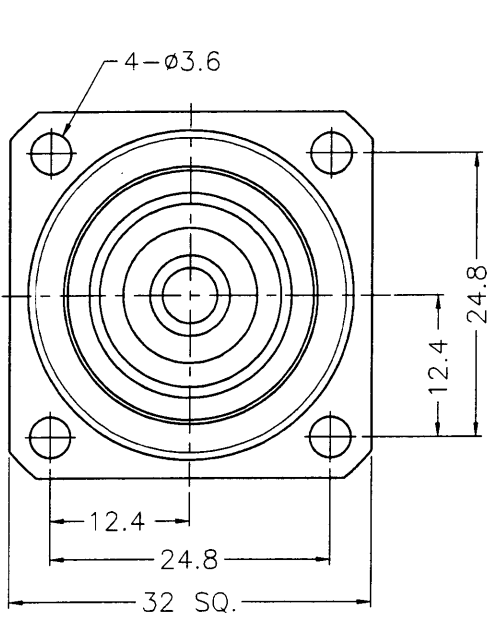

NOTES: FINISH (PLATING THICKNESS IN MICRO-INCHES)  
 1. BRASS PER QQ-B-626  
 2. SILVER PL. 120 MIN. THICK OVER COPPER STRIKE  
 3. BERYLLIUM COPPER PER QQ-C-530  
 4. SILVER PL. 200 MIN. THICK OVER COPPER STRIKE  
 5. TEFLON MIL-P-19468  
 6. BLUE, PER PANTONE 3005C

参考  
88.3.29  
開發部

試作  
88.3.26  
開發部

NO.	DESCRIPTION	MATERIAL	FINISH	Q'TY	DRAWING NO.
5	COVER	PE	NOTE 6	1	7166141A1-9
4	BODY	NOTE 1	NOTE 2	1	7166581A1-4 -.141
3	CONTACT PIN	NOTE 3	NOTE 4	1	7166581A1-3 -.141
2	INSULATOR	NOTE 5	NATURAL	1	7166581A1-2T -50-.141
1	BARREL	NOTE 1	NOTE 2	1	7166581A1-1 -467/364

DIMENSIONS ARE IN MILLIMETERS  
 UNLESS OTHERWISE SPECIFIED TOLERANCES  
 0.5-6 = ±0.2  
 6-30 = ±0.4  
 30-120 = ±0.6  
 120-315 = ±1  
 315-1000 = ±1.6  
 1000-2000 = ±2.4

PART NO.	
APPROVED	DATE 03-19-99'
CHECKED	DATE 03-19-99'
DRAWN	DATE 03-19-99'

<p><b>KAI JACK INDUSTRIAL CO., LTD.</b> TAINAN TAIWAN R.O.C.</p>	TITLE	7/16 SEMI-RIGID PANEL JACK (FOR .141")
	DRAWING NO.	KJ-7166581A1-120STS-.141-50
	FILE NO.	F:\DWG\716\6581A1\141\120STS

1 2 3 4 5 6 7 8