

1 2 3 4 5 6 7 8

REVISIONS		
ISS	ZONE	DESCRIPTION\PER REQUEST\DATE
B	A-1	NO.3 WAS CHANGED\RD-DM89071701Y\07-17-00'

業務部

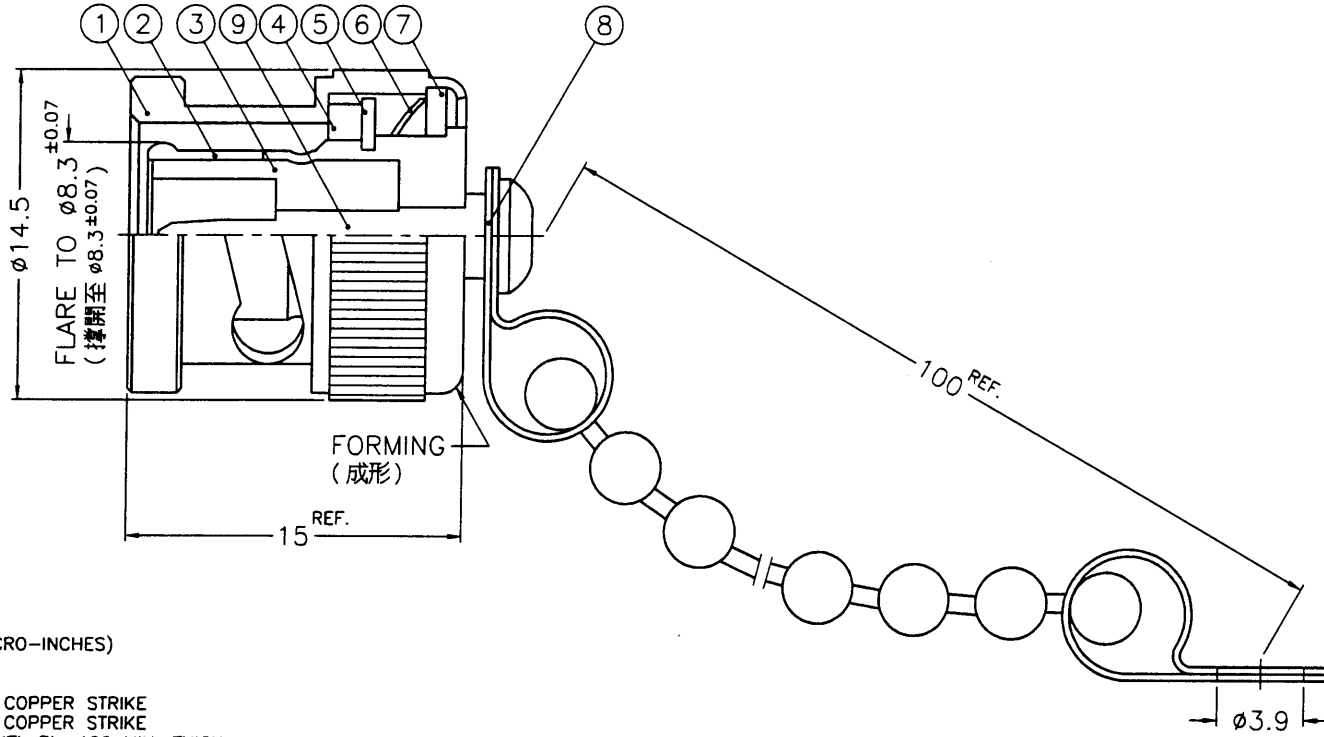

NOTES: FINISH (PLATING THICKNESS IN MICRO-INCHES)
 1. BRASS PER QQ-B-626
 2. BRASS PER QQ-B-613
 3. NICKEL PL. 100 MIN. THICK OVER COPPER STRIKE
 4. NICKEL PL. 200 MIN. THICK OVER COPPER STRIKE
 5. GOLD PL. 3 MIN. THICK OVER NICKEL PL. 100 MIN. THICK OVER COPPER STRIKE
 6. TEFLON MIL-P-19468

出圖
89.7.18
設計部

9	CONTACT PIN	NOTE 1	NOTE 5	1	202115-8
8	CHAIN	NOTE 1	NOTE 3	1	B500-4X100
7	WASHER	NOTE 2	NOTE 3	1	WS-128/9X08
6	SPRING	SK5	NOTE 4	1	B50000-6
5	RETAINER RING	NOTE 1	NOTE 3	1	B50000-5
4	GASKET	RUBBER	RED	1	GS-115/8X15
3	INSULATOR	NOTE 6	NATURAL	1	202115-3-B
2	BODY	NOTE 1	NOTE 3	1	202115-2
1	SHELL	NOTE 1	NOTE 3	1	B50000-1-B
NO.	DESCRIPTION	MATERIAL	FINISH	Q'TY	DRAWING NO.

DIMENSIONS ARE IN MILLIMETERS		PART NO.	
UNLESS OTHERWISE SPECIFIED TOLERANCES		APPROVED <i>Andy C</i> DATE 07-17-00'	
0.5-6 = ±0.2		CHECKED <i>Andy C</i> DATE 07-17-00'	
6-30 = ±0.4		DRAWN <i>Jojo Y</i> DATE 07-17-00'	
30-120 = ±0.6			
120-315 = ±1			
315-1000 = ±1.6			
1000-2000 = ±2.4			
SCALE	3/1	ISSUE	B

Amphenol - Kai Jack	
TAINAN TAIWAN	
TITLE	BNC SHORTING PLUG W/ CHAIN
DRAWING NO.	KJ-B1007A2-NT3G
FILE NO.	F:\DWG\B\1007A2\NT3G

F
E
D
C
B
A

F
E
D
C
B
A

1 2 3 4 5 6 7 8