

1 2 3 4 5 6 7 8

REVISIONS			
ISS	ZONE	DESCRIPTION	PER RECLST/DATE
A1	D-4	Ø4 WAS Ø4.2\N/A\09-16-99'	

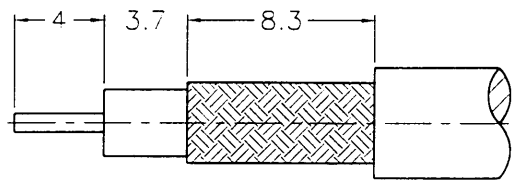

業務部

RECOMMENDED
CABLE STRIPPING DIM'S
(建議剝線尺寸)

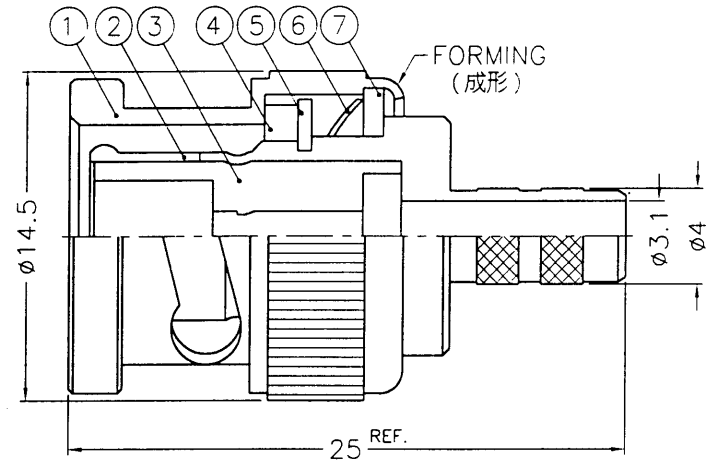
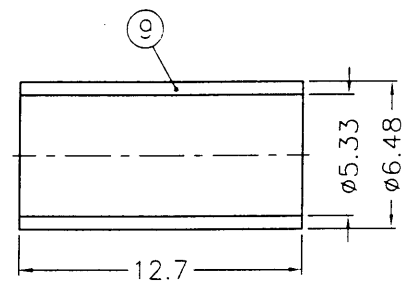
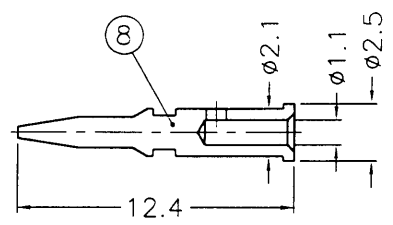

- NOTES: FINISH (PLATING THICKNESS IN MICRO-INCHES)
1. BRASS PER QQ-B-626
 2. BRASS PER QQ-B-613
 3. NICKEL PL. 100 MIN. THICK OVER COPPER STRIKE
 4. NICKEL PL. 200 MIN. THICK OVER COPPER STRIKE
 5. GOLD PL. 3 MIN. THICK OVER NICKEL PL. 100 MIN. THICK OVER COPPER STRIKE

1. CRIMPED FERRULE
HEX CRIMP SIZE .213"
2. CRIMPED CONTACT PIN
HEX CRIMP SIZE .068"



NO.	DESCRIPTION	MATERIAL	FINISH	Q'TY	DRAWING NO.
9	FERRULE	COPPER	NOTE 3	1	FR-648/533X127C
8	CONTACT PIN		NOTE 5	1	B50000-8-25/11
7	WASHER		NOTE 3	1	WS-128/ØXØ8
6	SPRING	SK5	NOTE 4	1	B50000-6
5	RETAINER RING		NOTE 3	1	B50000-5
4	GASKET	RUBBER	RED	1	GS-115/ØX15
3	INSULATOR	DELTRIN	NATURAL	1	B50000-3-50-A
2	BODY		NOTE 3	1	B50000-2-4/31
1	SHELL		NOTE 3	1	B50000-1-B

DIMENSIONS ARE IN MILLIMETERS
UNLESS OTHERWISE SPECIFIED
TOLERANCES
0.5-6 = ±0.2
6-30 = ±0.4
30-120 = ±0.6
120-315 = ±1
315-1000 = ±1.6
1000-2000 = ±2.4

PART NO.	
APPROVED	DATE 09-16-99'
CHECKED	DATE 09-16-99'
DRAWN	DATE 09-16-99'

Amphenol - Kai Jack	
TAINAN TAIWAN	
TITLE	BNC CRIMP PLUG
DRAWING NO.	KJ-B1121A1-ND3G-142AU-50
FILE NO.	F:\DWG\B\1121A1\142AU-50\ND3G

F
E
D
C
B
A

F
E
D
C
B
A

1 2 3 4 5 6 7 8

BR5779