

REVISIONS		
ISS	ZONE	DESCRIPTION\APPROVED\DATE
A	A-7	B1121A1 WAS B50000\TONY. T\03-02-93'
B	A-1	NO.3 WAS CHANGED\TONY. T\02-03-94'
C	A-1	NO.1 WAS CHANGED\TONY. T\12-30-94'
D	A-1	DRAWING NO. WERE CHANGED ON NO.2, NO.4, NO.7,
	B-1	NO.8 AND NO.9\TONY. T\09-23-96'

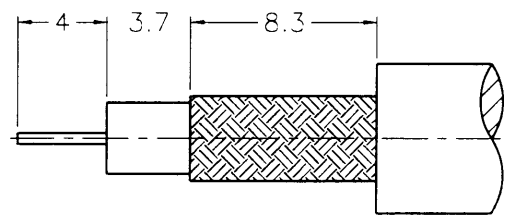

RECOMMENDED
CABLE STRIPPING DIM'S

業務部

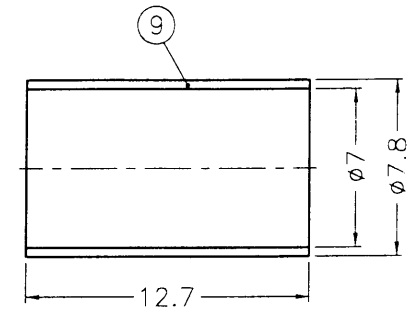
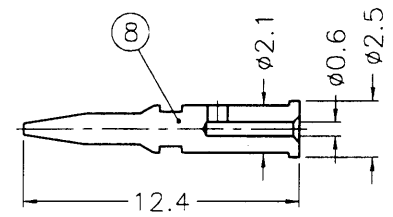
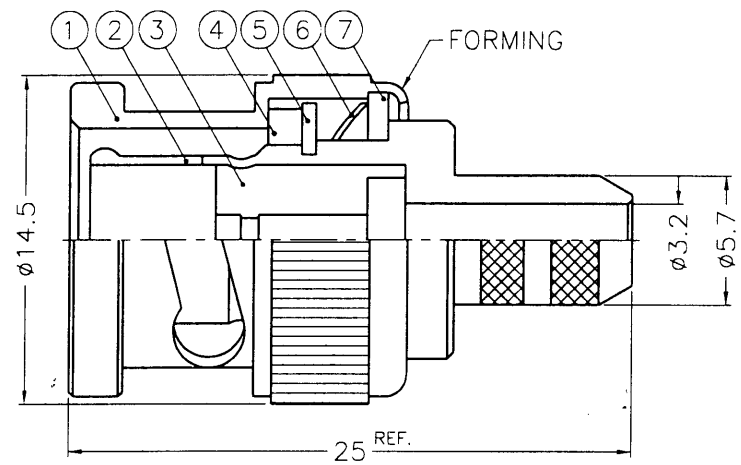

- NOTES: 1. PER KAI JACK SPEC. EP-SS-9700
 2. BRASS PER QQ-B-626
 3. BRASS PER QQ-B-613
 4. DELRIN 500F (B50000-3-75-A)
 TEFLON MIL-P-19468 (B50000-3T-75)
 5. JIS H 3250, C 2700

出圖
87.3.20
R&D

NO.	DESCRIPTION	MATERIAL	FINISH	Q'TY	DRAWING NO.
9	FERRULE			1	FR-78/7X127
8	CONTACT PIN			1	B50000-8-25/06
7	WASHER			1	WS-128/9X08
6	SPRING	SK5		1	B50000-6
5	RETAINER RING			1	B50000-5
4	GASKET	RUBBER	RED	1	GS-115/8X15
3	INSULATOR		NATURAL	1	NOTE 4
2	BODY			1	B50000-2-57/32
1	SHELL			1	B50000-1-B

DIMENSIONS ARE IN MILLIMETERS
 UNLESS OTHERWISE SPECIFIED
 TOLERANCES
 0.5-6 = ±0.2
 6-30 = ±0.4
 30-120 = ±0.6
 120-315 = ±1
 315-1000 = ±1.6
 1000-2000 = ±2.4

PART NO.	
APPROVED	DATE 03-19-98'
CHECKED	DATE 03-19-98'
DRAWN	DATE 03-19-98'



KAI JACK INDUSTRIAL CO., LTD.
TAINAN TAIWAN R.O.C.

TITLE	
BNC CRIMP PLUG	
DRAWING NO. KJ-B1121A1-3C2W-75	
FILE NO. F:\DWG\B\1121A1\3C2W-75	