

REVISIONS		
ISS	ZONE	DESCRIPTION\PER REQUEST\DATE

業務部

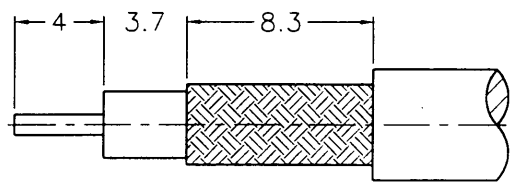

RECOMMENDED  
CABLE STRIPPING DIM'S

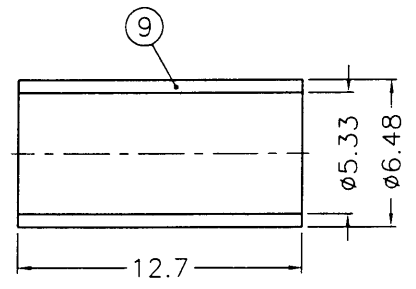
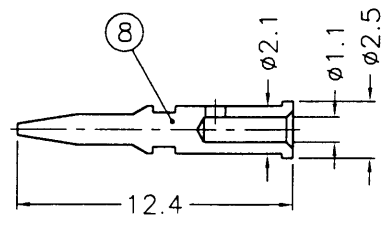
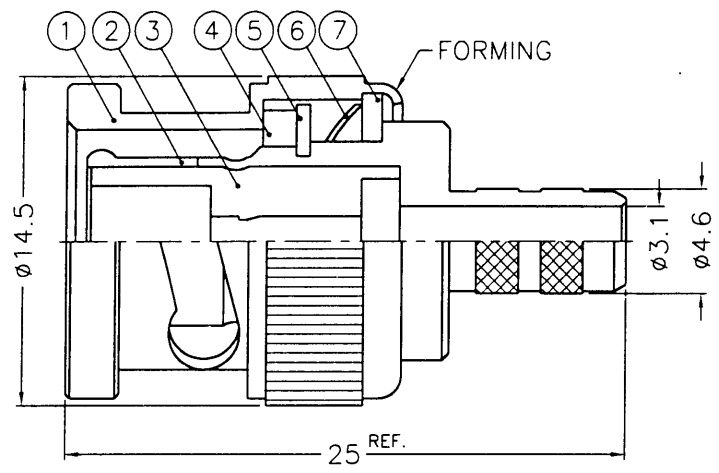

- NOTES: FINISH (PLATING THICKNESS IN MICRO-INCHES)
- BRASS PER QQ-B-626
  - BRASS PER QQ-B-613
  - NICKEL PL. 100 MIN. THICK OVER COPPER STRIKE
  - NICKEL PL. 200 MIN. THICK OVER COPPER STRIKE
  - GOLD PL. 3 MIN. THICK OVER NICKEL PL. 100 MIN. THICK OVER COPPER STRIKE

出圖  
88.5.03  
R & D

NO.	DESCRIPTION	MATERIAL	FINISH	Q'TY	DRAWING NO.
9	FERRULE	COPPER	NOTE 3	1	FR-648/533X127C
8	CONTACT PIN	NOTE 1	NOTE 5	1	B50000-8-25/11
7	WASHER	NOTE 2	NOTE 3	1	WS-128/9X08
6	SPRING	SK5	NOTE 4	1	B50000-6
5	RETAINER RING	NOTE 1	NOTE 3	1	B50000-5
4	GASKET	RUBBER	RED	1	GS-115/8X15
3	INSULATOR	DELTRIN	NATURAL	1	B50000-3-50-A
2	BODY	NOTE 1	NOTE 3	1	B50000-2-46/31
1	SHELL	NOTE 1	NOTE 3	1	B50000-1-B

DIMENSIONS ARE IN MILLIMETERS  
UNLESS OTHERWISE SPECIFIED TOLERANCES

0.5-6 = ±0.2  
6-30 = ±0.4  
30-120 = ±0.6  
120-315 = ±1  
315-1000 = ±1.6  
1000-2000 = ±2.4

PART NO.	DATE
APPROVED <i>Mark C</i>	04-30-99'
CHECKED <i>Mark C</i>	04-30-99'
DRAWN <i>Ada</i>	04-30-99'

	<b>KAI JACK INDUSTRIAL CO., LTD.</b> TAINAN TAIWAN R.O.C.
TITLE	BNC CRIMP PLUG
DRAWING NO.	KJ-B1121A1-ND3G-58CU-50
FILE NO.	F:\DWG\B\1121A1\58CU-50\ND3G

F  
E  
D  
C  
B  
A

F  
E  
D  
C  
E  
A

882408