

1 2 3 4 5 6 7 8

REVISIONS			
ISS	ZONE	DESCRIPTION\PER REQUEST\DATE	
A1	D-1	ADDED FLARE\N/A\02-16-00'	

SALES

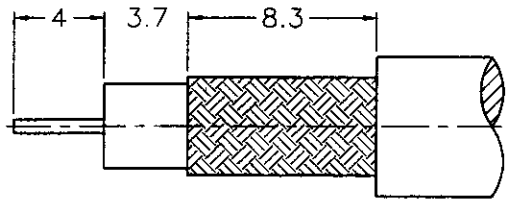

RECOMMENDED
CABLE STRIPPING DIM'S
(建議剝線尺寸)

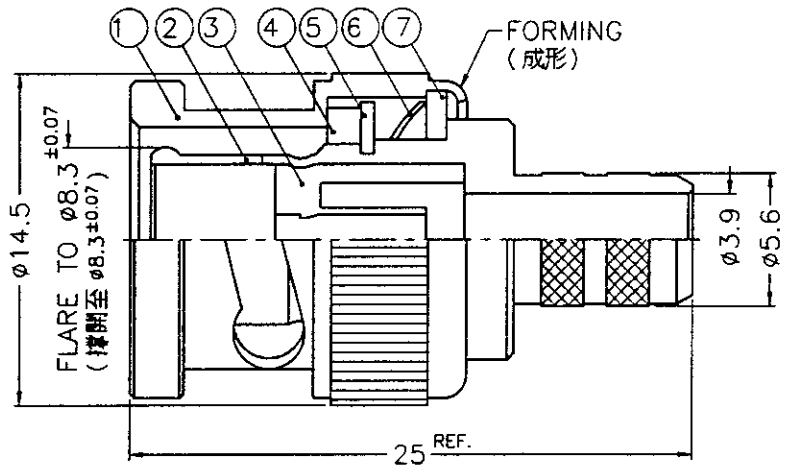
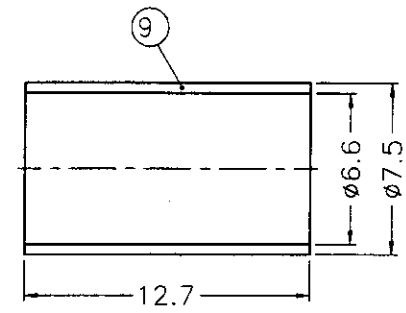
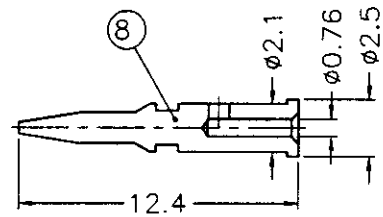

- NOTES: FINISH (PLATING THICKNESS IN MICRO-INCHES)
- BRASS PER QQ-8-626
 - BRASS PER QQ-8-613
 - NICKEL PL. 100 MIN. THICK OVER COPPER STRIKE
 - NICKEL PL. 200 MIN. THICK OVER COPPER STRIKE
 - GOLD PL. 3 MIN. THICK OVER NICKEL PL. 100 MIN. THICK OVER COPPER STRIKE
 - JIS H 3250, C 2700

- CRIMPED FERRULE
HEX CRIMP SIZE .255"
- CRIMPED CONTACT PIN
HEX CRIMP SIZE .068"

ISSUED
2000. 2. 21
R&D

NO.	DESCRIPTION	MATERIAL	FINISH	Q'TY	DRAWING NO.
9	FERRULE			1	FR-75/66X127
8	CONTACT PIN			1	B50000-8-25/076
7	WASHER			1	WS-128/9X08
6	SPRING			1	B50000-6
5	RETAINER RING			1	B50000-5
4	GASKET	RUBBER	RED	1	GS-115/8X15
3	INSULATOR	DELTRIN	NATURAL	1	B50000-3-75-A
2	BODY			1	B50000-2-56/39
1	SHELL			1	B50000-1-B

DIMENSIONS ARE IN MILLIMETERS
UNLESS OTHERWISE SPECIFIED TOLERANCES

0.5-6	= ±0.2
6-30	= ±0.4
30-120	= ±0.6
120-315	= ±1
315-1000	= ±1.6
1000-2000	= ±2.4

PART NO.	
APPROVED	DATE 02-16-00'
CHECKED	DATE 02-16-00'
DRAWN	DATE 02-16-00'

Amphenol - Kai Jack	
TAINAN TAIWAN	
TITLE	BNC CRIMP PLUG
DRAWING NO.	KJ-B1121A1-ND3G-59U-75
FILE NO.	F:\DWG\B\1121A1\59U-75\ND3G

F
E
D
C
B
A

F
E
D
C
B
A