

1 2 3 4 5 6 7 8

REVISIONS		
ISS	ZONE	DESCRIPTION\PER REQUEST\DATE

業務部

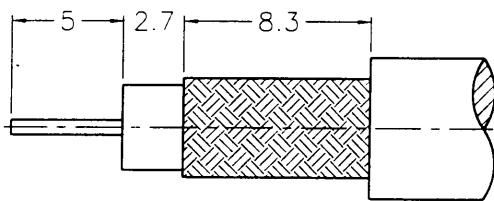

RECOMMENDED
CABLE STRIPPING DIM'S

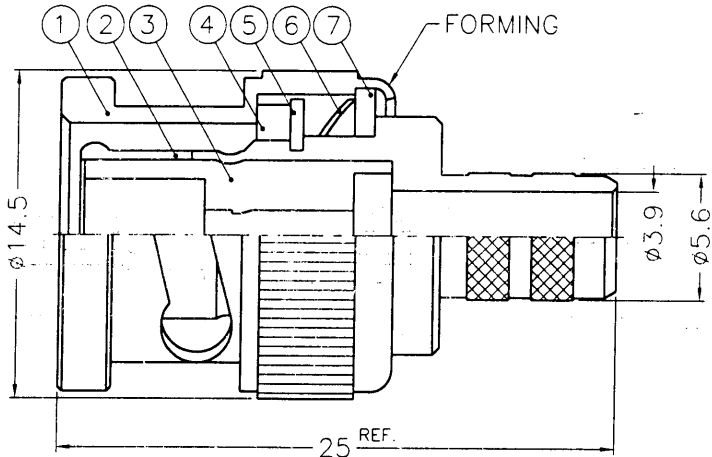
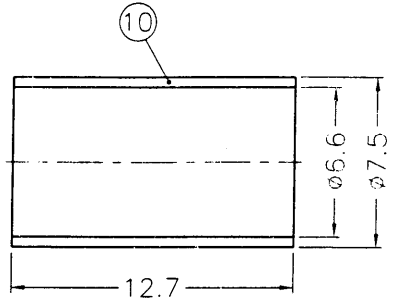
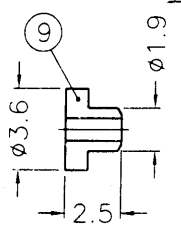
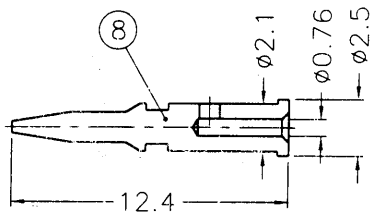

NOTES: FINISH (PLATING THICKNESS IN MICRO-INCHES)
 1. BRASS PER QQ-B-626
 2. BRASS PER QQ-B-613
 3. NICKEL PL. 100 MIN. THICK OVER COPPER STRIKE
 4. NICKEL PL. 200 MIN. THICK OVER COPPER STRIKE
 5. GOLD PL. 3 MIN. THICK OVER NICKEL PL. 100 MIN. THICK OVER COPPER STRIKE
 6. JIS H 3250, C 2700

88.4.02
R & D

10	FERRULE	NOTE 6	NOTE 3	1	FR-75/66X127
9	INSULATOR	DELTRIN	NATURAL	1	B50000-11-36/1
8	CONTACT PIN	NOTE 1	NOTE 5	1	B50000-8-25/076
7	WASHER	NOTE 2	NOTE 3	1	WS-128/9X08
6	SPRING	SK5	NOTE 4	1	B50000-6
5	RETAINER RING	NOTE 1	NOTE 3	1	B50000-5
4	GASKET	RUBBER	RED	1	GS-115/8X15
3	INSULATOR	DELTRIN	NATURAL	1	B50000-3-50-A
2	BODY	NOTE 1	NOTE 3	1	B50000-2-56/39
1	SHELL	NOTE 1	NOTE 3	1	B50000-1-B

DIMENSIONS ARE IN MILLIMETERS		PART NO.	
UNLESS OTHERWISE SPECIFIED TOLERANCES		APPROVED <i>Mark C</i> DATE 04-01-99'	
0.5-6 = ±0.2		CHECKED <i>Mark C</i> DATE 04-01-99'	
6-30 = ±0.4		DRAWN <i>Allen</i> DATE 04-01-99'	
30-120 = ±0.6			
120-315 = ±1			
315-1000 = ±1.6			
1000-2000 = ±2.4			

KAI JACK INDUSTRIAL CO., LTD. TAINAN TAIWAN R.O.C.	
TITLE BNC CRIMP PLUG	
DRAWING NO. KJ-B1121A1-ND3G-62AU-50	
FILE NO. F:\DWG\B\1121A1\62AU-50\ND3G	

NO.	DESCRIPTION	MATERIAL	FINISH	Q'TY	DRAWING NO.
-----	-------------	----------	--------	------	-------------

1 2 3 4 5 6 7 8 88R039