

REVISIONS		
ISS	ZONE	DESCRIPTION\PER REQUEST\DATE

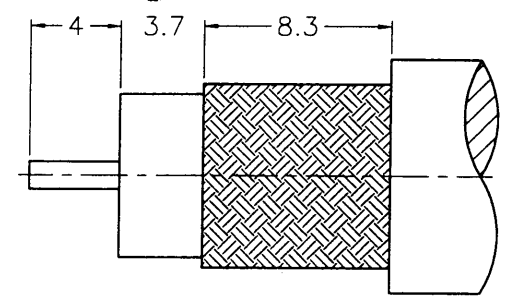

RECOMMENDED
CABLE STRIPPING DIM'S
(建議剝線尺寸)

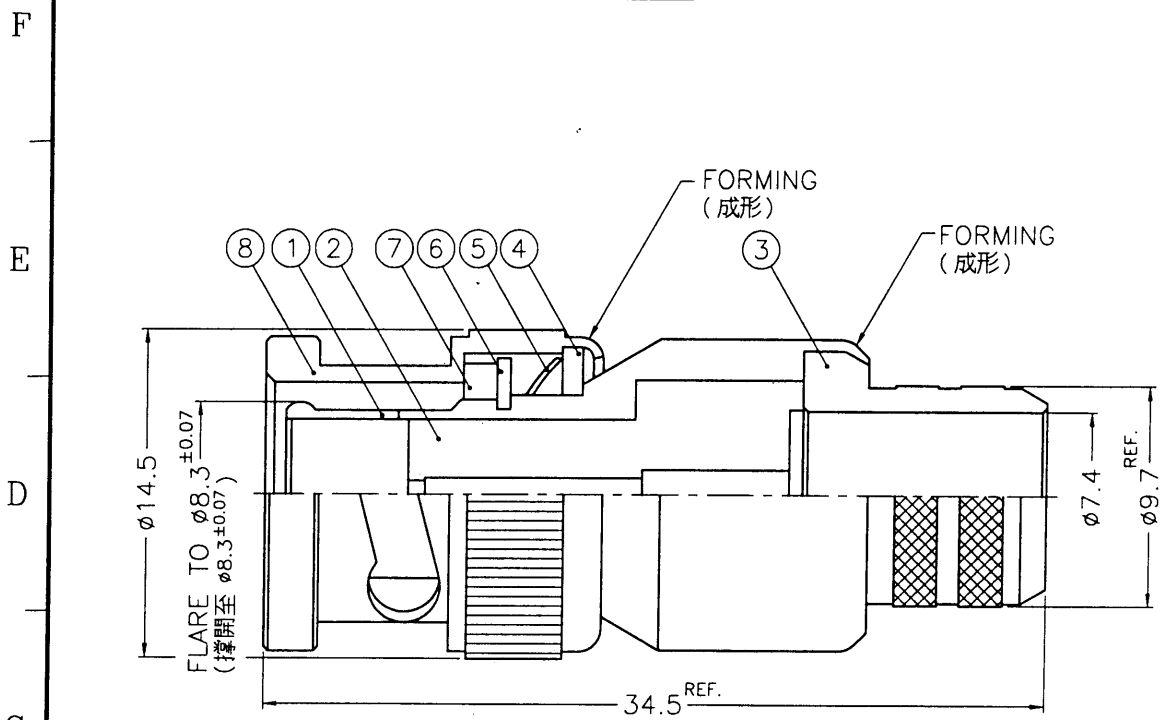
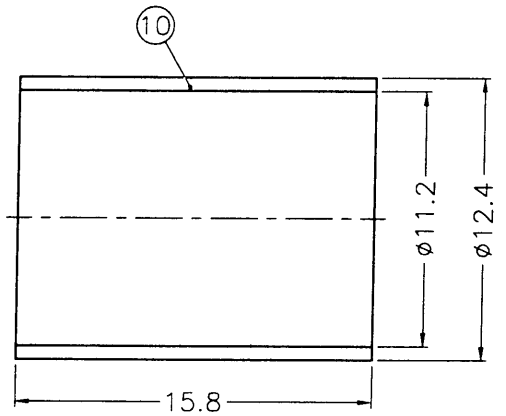
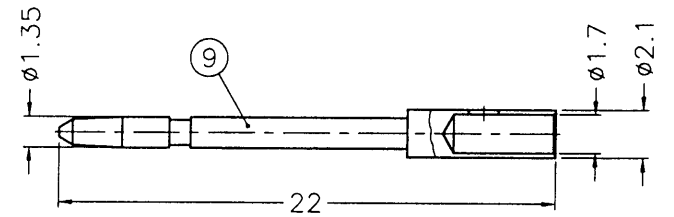

- NOTES: FINISH (PLATING THICKNESS IN MICRO-INCHES)
1. BRASS PER QQ-B-626
 2. BRASS PER QQ-B-613
 3. NICKEL PL. 100 MIN. THICK OVER COPPER STRIKE
 4. NICKEL PL. 200 MIN. THICK OVER COPPER STRIKE
 5. GOLD PL. 3 MIN. THICK OVER NICKEL PL. 100 MIN. THICK OVER COPPER STRIKE
 6. TEFLON MIL-P-19468
 7. JIS H 3250, C 2600

1. CRIMPED FERRULE
HEX CRIMP SIZE .429"
2. CRIMPED CONTACT PIN
HEX CRIMP SIZE .068"

10	FERRULE	NOTE 7	NOTE 3	1	FR-124/112X158
9	CONTACT PIN	NOTE 1	NOTE 5	1	B1141A2-13-21/17
8	SHELL	NOTE 1	NOTE 3	1	B50000-1-B
7	GASKET	RUBBER	RED	1	GS-115/BX15
6	RETAINER RING	NOTE 1	NOTE 3	1	B50000-5
5	SPRING	SK5	NOTE 4	1	B50000-6
4	WASHER	NOTE 2	NOTE 3	1	WS-128/9X08
3	BARREL	NOTE 1	NOTE 3	1	BR00ABT18A
2	INSULATOR	NOTE 6	NATURAL	1	B1141A2-3T-75
1	BODY	NOTE 1	NOTE 3	1	B1121A6-2
NO.	DESCRIPTION	MATERIAL	FINISH	Q'TY	DRAWING NO.

DIMENSIONS ARE IN MILLIMETERS				PART NO.	1004053
UNLESS OTHERWISE SPECIFIED TOLERANCES				APPROVED	<i>Kaly</i>
0.5-6	= ±0.2	6-30	= ±0.4	DATE	01-20-03'
30-120	= ±0.6	120-315	= ±1	CHECKED	<i>Kaly</i>
315-1000	= ±1.6	1000-2000	= ±2.4	DATE	01-20-03'
SCALE	3/1	ISSUE	A1	DRAWN	ANGELA
FILE NO.	F:\DWG\B\1121A6\005\75\NT3G				

Amphenol	
Danbury, CT, USA - Tainan, Taiwan - Shenzhen, China	
TITLE	BNC CRIMP PLUG
DRAWING NO.	B1121A6-005-NT3G-75
ITEM NO.	