

1 2 3 4 5 6 7 8

REVISIONS			
ISS	ZONE	DESCRIPTION	PER REQUEST DATE

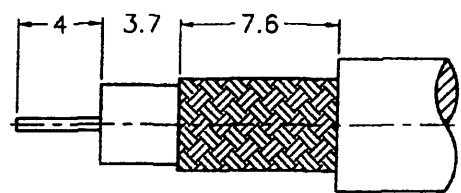

RECOMMENDED
CABLE STRIPPING DIM'S
(建議剝線尺寸)

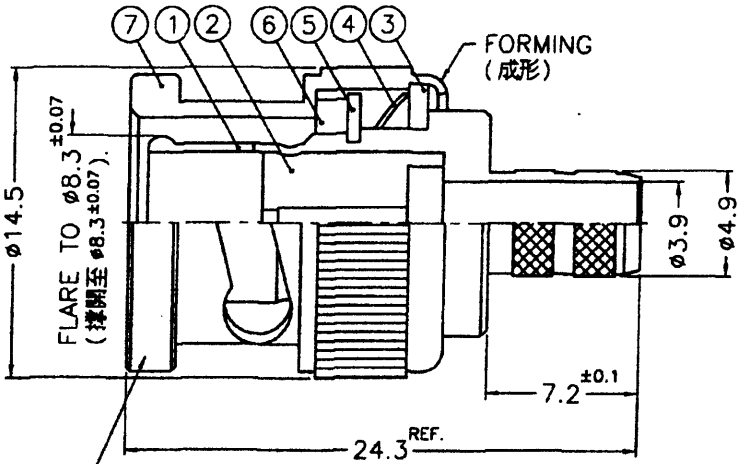
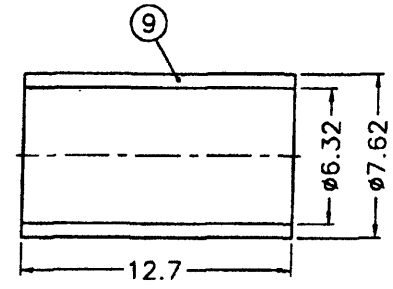
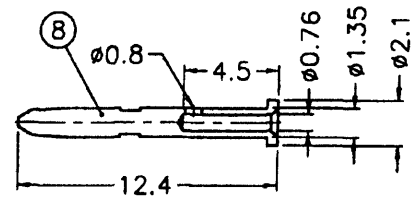

THIS DRAWING HAS APPROVED BY:

CUSTOMER SIGNATURE
DATE: _____

- NOTES: FINISH (PLATING THICKNESS IN MICRO-INCHES)
- BRASS PER QQ-B-626
 - BRASS PER QQ-B-613
 - NICKEL PL. 100 MIN. THICK OVER COPPER STRIKE
 - NICKEL PL. 200 MIN. THICK OVER COPPER STRIKE
 - GOLD PL. 50 MIN. THICK OVER NICKEL PL. 100 MIN. THICK OVER COPPER STRIKE
 - TEFLON MIL-P-19468
 - JIS H 3250, C 2600



1. CRIMPED CONTACT PIN
SQ. CRIMP SIZE .042"/.043"

9	FERRULE	NOTE 7	NOTE 3	1	FRO0AAC99A
8	CONTACT PIN	NOTE 1	NOTE 5	1	10-03001-204-8-0.76-8
7	SHELL	NOTE 1	NOTE 3	1	B50000-1-B
6	GASKET	RUBBER	RED	1	GS-115/8X15
5	RETAINER RING	NOTE 1	NOTE 3	1	B50000-5
4	SPRING	SK5	NOTE 4	1	B50000-6
3	WASHER	NOTE 2	NOTE 3	1	WS-128/9X08
2	INSULATOR	NOTE 6	NATURAL	1	10-03001-204-3-A
1	BODY	NOTE 1	NOTE 3	1	B001----
NO.	DESCRIPTION	MATERIAL	FINISH	Q'TY	DRAWING NO.

DIMENSIONS ARE IN MILLIMETERS
UNLESS OTHERWISE SPECIFIED TOLERANCES
0.5-6 = ±0.2
6-30 = ±0.4
30-120 = ±0.6
120-315 = ±1
315-1000 = ±1.6
1000-2000 = ±2.4

PART NO.	895H751	
APPROVED	<i>Karly</i>	DATE 08-01-03'
CHECKED	<i>Karly</i>	DATE 08-01-03'
DRAWN	ANGELA	DATE 08-01-03'
FILE NO.	F:\DWG\B\1121A9\043\75\NT50G-A2	

Amphenol	
Danbury, CT, USA - Tainan, Taiwan - Shenzhen, China	
TITLE	BNC CRIMP PLUG
DRAWING NO.	B1121A9-043-NT50G-75
ITEM NO.	01121Aafb7NE7F

F
E
D
C
B
A

F
E
D
C
B
A

1 2 3 4 5 6 7 8