

REVISIONS		
ISS	ZONE	DESCRIPTION\PER REQUEST\DATE

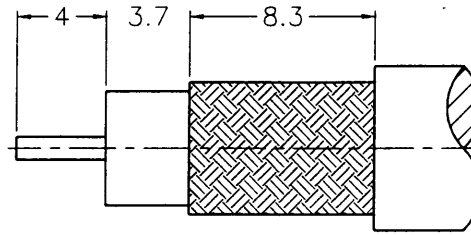

RECOMMENDED  
CABLE STRIPPING DIM'S  
(建議剝線尺寸)

業務部

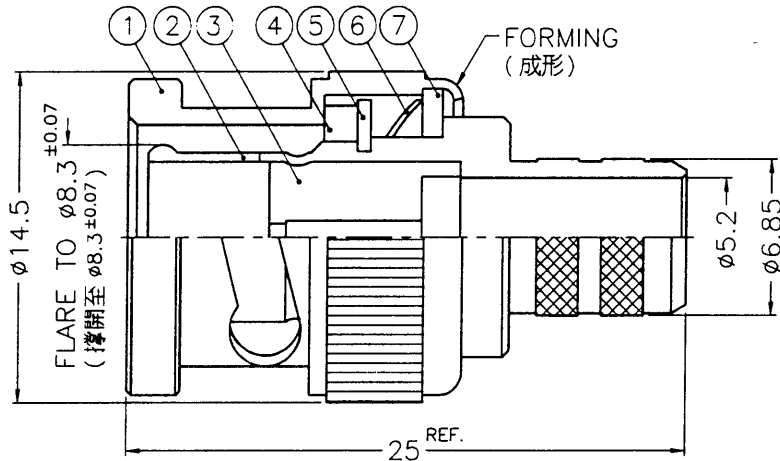
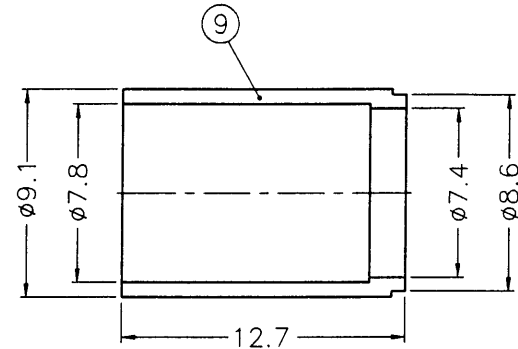
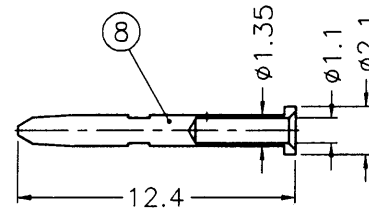

NOTES: FINISH (PLATING THICKNESS IN MICRO-INCHES)

1. BRASS PER QQ-B-626
2. BRASS PER QQ-B-613
3. NICKEL PL. 100 MIN. THICK OVER COPPER STRIKE
4. NICKEL PL. 200 MIN. THICK OVER COPPER STRIKE
5. GOLD PL. 3 MIN. THICK OVER NICKEL PL. 100 MIN. THICK OVER COPPER STRIKE
6. TEFLON MIL-P-19468
7. JIS H3260, C 3501



1. CRIMPED FERRULE  
HEX CRIMP SIZE .319"
2. CRIMPED CONTACT PIN  
SQ. CRIMP SIZE .043"

NO.	DESCRIPTION	MATERIAL	FINISH	Q'TY	DRAWING NO.
9	FERRULE	NOTE 7	NOTE 3	1	FR-91/78-86/74 X127
8	CONTACT PIN	NOTE 1	NOTE 5	1	10-03001-204-8-1.1
7	WASHER	NOTE 2	NOTE 3	1	WS-128/9X08
6	SPRING	SK5	NOTE 4	1	B50000-6
5	RETAINER RING	NOTE 1	NOTE 3	1	B50000-5
4	GASKET	RUBBER	RED	1	GS-115/8X15
3	INSULATOR	NOTE 6	NATURAL	1	10-03001-204-3-A
2	BODY	NOTE 1	NOTE 3	1	B50000-2-685/52
1	SHELL	NOTE 1	NOTE 3	1	B50000-1-B

DIMENSIONS ARE IN MILLIMETERS				PART NO.	
UNLESS OTHERWISE SPECIFIED TOLERANCES				APPROVED <i>Mark C</i> DATE 09-08-00'	
0.5-6	=	±0.2	CHECKED <i>Jarcky</i> DATE 09-08-00'		
6-30	=	±0.4	DRAWN <i>ka</i> DATE 09-08-00'		
30-120	=	±0.6	SCALE 3/1 ISSUE A		
120-315	=	±1	FILE NO. F:\DWG\B\1121A9\1694A-75\NT3G		
315-1000	=	±1.6			
1000-2000	=	±2.4			

Amphenol - Kai Jack	
TAINAN TAIWAN	
TITLE	BNC CRIMP PLUG (FOR BELDEN 1694A CABLE)
DRAWING NO.	KJ-B1121A9-NT3G-1694A-75
FILE NO.	F:\DWG\B\1121A9\1694A-75\NT3G

F  
E  
D  
C  
B  
A

F  
E  
D  
C  
B  
A