

ISS ZONE	DESCRIPTION \ PER REQUEST \ DATE
A1	B-7 CRIMP TOOL WAS CHANGED \ N/A \ 03-22-01'

業務部

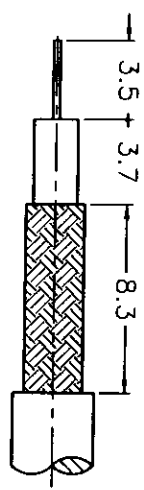

RECOMMENDED
CABLE STRIPPING DIM'S
(建議剝線尺寸)

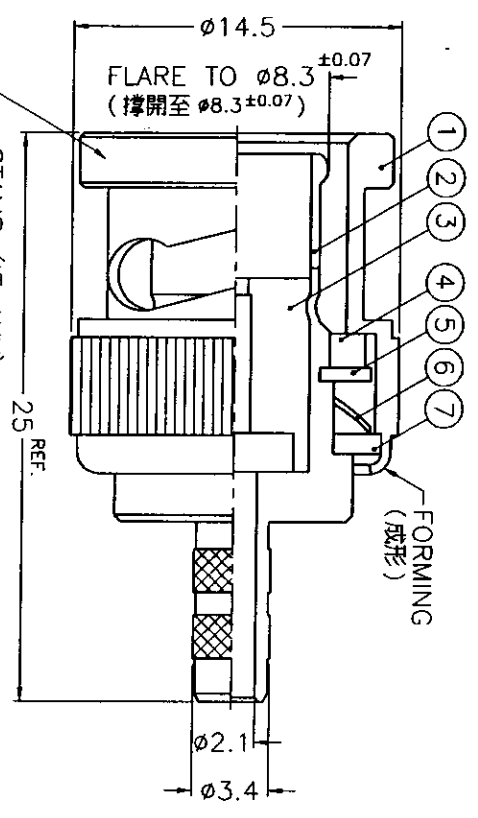
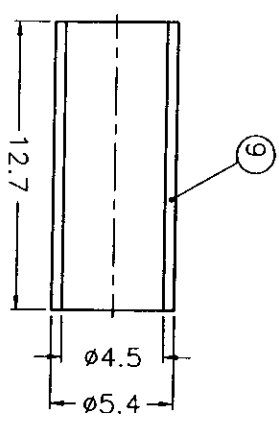
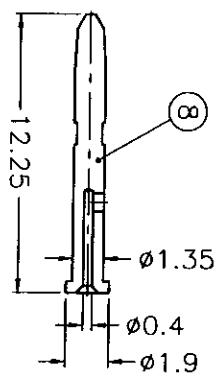

STAMP (IF ANY)
噴字 (若有要求)

NOTES: FINISH (PLATING THICKNESS IN MICRO-INCHES)

1. BRASS PER QQ-B-626
2. BRASS PER QQ-B-613
3. NICKEL PL. 100 MIN. THICK OVER COPPER STRIKE
4. NICKEL PL. 200 MIN. THICK OVER COPPER STRIKE
5. GOLD PL. 3 MIN. THICK OVER NICKEL PL. 100 MIN. THICK OVER COPPER STRIKE
6. TEFLON MIL-P-19468
7. JIS H 3250, C 2700

1. CRIMPED FERRULE
HEX CRIMP SIZE .178"
2. CRIMPED CONTACT PIN
SQ. CRIMP SIZE .042"



9	FERRULE	NOTE 7	NOTE 3	1	FR-54/45X127
8	CONTACT PIN	NOTE 1	NOTE 5	1	B1121A9-8-19
7	WASHER	NOTE 2	NOTE 3	1	WS-128/9X08
6	SPRING	SKS	NOTE 4	1	BS0000-6
5	RETAINER RING	NOTE 1	NOTE 3	1	BS0000-5
4	GASKET	RUBBER	RED	1	GS-115/8X15
3	INSULATOR	NOTE 6	NATURAL	1	10-03001-204-3-A
2	BODY	NOTE 1	NOTE 3	1	BS0000-2-34/21
1	SHELL	NOTE 1	NOTE 3	1	BS0000-1-B

DIMENSIONS ARE IN MILLIMETERS
UNLESS OTHERWISE SPECIFIED
TOLERANCES

0.5-6	= ±0.2
6-30	= ±0.4
30-120	= ±0.6
120-315	= ±1
315-1000	= ±1.6
1000-2000	= ±2.4

PART NO.		APPROVED	
UNLESS OTHERWISE SPECIFIED		<i>[Signature]</i>	
DATE	DATE	DATE	DATE
03-22-01'	03-22-01'	03-22-01'	03-22-01'
CHECKED		DRAWN	
<i>[Signature]</i>		<i>[Signature]</i>	
DATE		DATE	
03-22-01'		03-22-01'	

TITLE	
Amphenol - Kai Jack	
TAINAN TAIWAN	
DRAWING NO.	
KJ-B1121A9-NT3G-BT3002-75	
FILE NO.	F:\DWG\B\1121A9\BT300275\NT3G

RD BRK 11880