

1 2 3 4 5 6 7 8

REVISIONS		
ISS	ZONE	DESCRIPTION\APPROVED\DATE

業務部

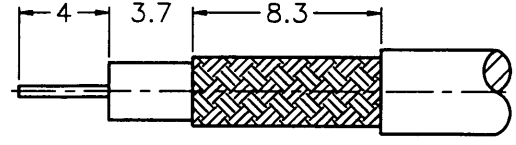

RECOMMENDED
CABLE STRIPPING DIM'S

F
E
D
C
B
A

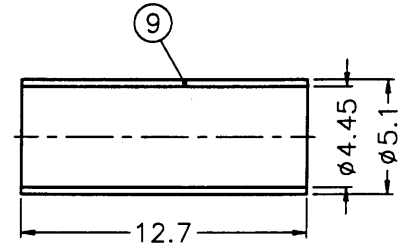
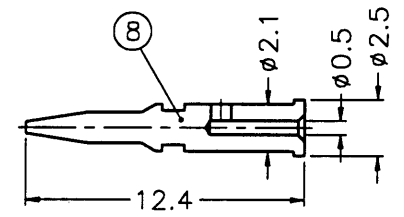
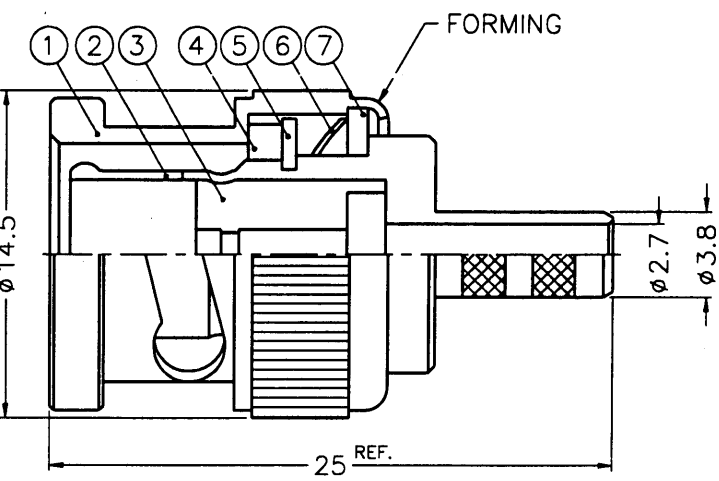

- NOTES: FINISH (PLATING THICKNESS IN MICRO-INCHES)
- BRASS PER QQ-B-626, ALLOY 360, 1/2 H
 - BRASS PER QQ-B-613, COMP 260, HARD TEMP
 - NICKEL PL. 100 MIN. OVER COPPER PL. 50 MIN. SILVER PL. 80 MIN. OVER COPPER PL. 50 MIN.
 - GOLD PL. MIN. OVER NICKEL PL. 50 MIN. OVER COPPER PL. 50 MIN. SILVER PL. 100 MIN. OVER NICKEL PL. 50 MIN. OVER COPPER PL. 50 MIN.
 - DELRIN 500F (B50000-3-75-A) TEFLON MIL-P-19468 (B50000-3T-75)

出圖
86.5.13
R&D

9	FERRULE	NOTE 1	NOTE 3	1	FR-51/445X127
8	CONTACT PIN	NOTE 1	NOTE 4	1	B50000-8-25/05
7	WASHER	NOTE 2	NOTE 3	1	WS-12B/9X08
6	SPRING	SK5	NOTE 3	1	B50000-6
5	RETAINER RING	NOTE 1	NOTE 3	1	B50000-5
4	GASKET	RUBBER	RED	1	GS-115/8X15
3	INSULATOR	NOTE 5	NATURAL	1	NOTE 5
2	BODY	NOTE 1	NOTE 3	1	B50000-2-38/27
1	SHELL	DIECAST	NOTE 3	1	B50000Z-1
NO.	DESCRIPTION	MATERIAL	FINISH	Q'TY	DRAWING NO.

DIMENSIONS ARE IN MILLIMETERS
UNLESS OTHERWISE SPECIFIED TOLERANCES
0.5-6 = ±0.2
6-30 = ±0.4
30-120 = ±0.6
120-315 = ±1
315-1000 = ±1.6
1000-2000 = ±2.4

PART NO.	
APPROVED	DATE 05-09-97'
CHECKED	DATE 05-09-97'
DRAWN	DATE 05-09-97'

KAI JACK INDUSTRIAL CO., LTD. TAINAN TAIWAN R.O.C.	
TITLE BNC CRIMP PLUG	
DRAWING NO. KJ-B1121B1-2.5C2V-75	
FILE NO. F:\DWG\B\1121B1\25C2V-75	

1 2 3 4 5 6 7 8