

REVISIONS		
ISS	ZONE	DESCRIPTION\PER REQUEST\DATE

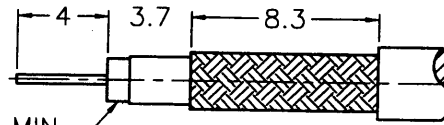

REMOVE FOIL 1mm MIN.
(去除箔襯1mm以上)

RECOMMENDED
CABLE STRIPPING DIM'S
(建議剝線尺寸)

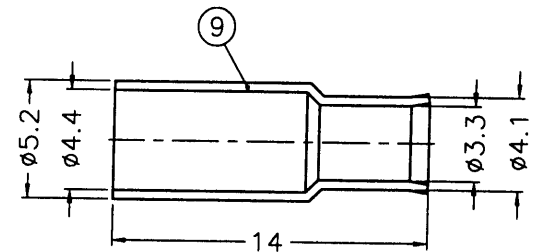
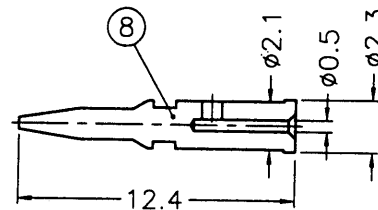
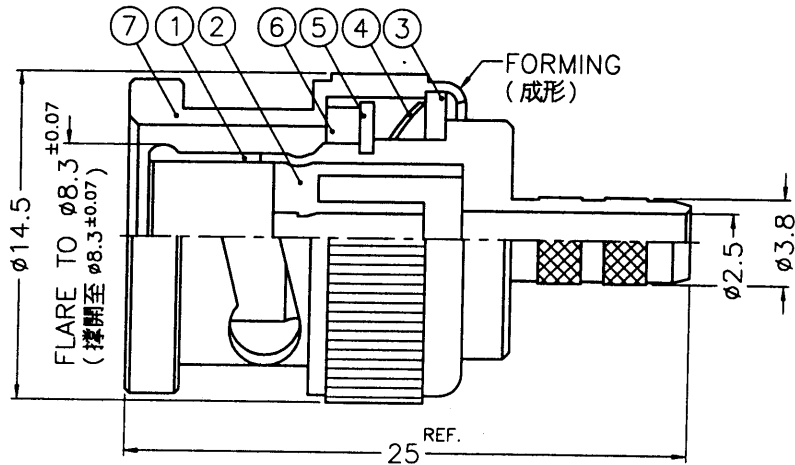

NOTES: FINISH (PLATING THICKNESS IN MICRO-INCHES)

- BRASS PER QQ-B-626
- BRASS PER QQ-B-613
- NICKEL PL. 100 MIN. THICK OVER COPPER PL. 300 MIN. THICK
- NICKEL PL. 100 MIN. THICK OVER COPPER STRIKE
- NICKEL PL. 200 MIN. THICK OVER COPPER STRIKE
- GOLD PL. 3 MIN. OVER NICKEL PL. 100 MIN. THICK OVER COPPER STRIKE
- ZINC DIECAST

- CRIMPED FERRULE
HEX CRIMP SIZE .178"
- CRIMPED CONTACT PIN
HEX CRIMP SIZE .068"



9	FERRULE	NOTE 1	NOTE 4	1	FR-52/44-41/33 X14
8	CONTACT PIN	NOTE 1	NOTE 6	1	B50000-8-23/05
7	SHELL	NOTE 7	NOTE 3	1	B50000Z-1
6	GASKET	RUBBER	RED	1	GS-115/8X15
5	RETAINER RING	NOTE 1	NOTE 4	1	B50000-5
4	SPRING	SK5	NOTE 5	1	B50000-6
3	WASHER	NOTE 2	NOTE 4	1	WS-128/9X08
2	INSULATOR	DELRIN	NATURAL	1	B50000-3-75-A
1	BODY	NOTE 1	NOTE 4	1	B50000-2-38/25
NO.	DESCRIPTION	MATERIAL	FINISH	Q'TY	DRAWING NO.

DIMENSIONS ARE IN MILLIMETERS
UNLESS OTHERWISE SPECIFIED
TOLERANCES
0.5-6 = ±0.2
6-30 = ±0.4
30-120 = ±0.6
120-315 = ±1
315-1000 = ±1.6
1000-2000 = ±2.4

PART NO.	
APPROVED	DATE
CHECKED	DATE
DRAWN	DATE
FILE NO.	F:\DWG\B\1121B1\2C2V-75\ND3G

Amphenol	
Danbury,CT,USA-Tainan,Taiwan-Shenzhen,China	
TITLE BNC CRIMP PLUG	
DRAWING NO. B1121B1-ND3G-2C2V-75	
ITEM NO.	

