

REVISIONS				
ISS	ZONE	DESCRIPTION	APPROVED	DATE
A	A-7	B1121E1 WAS B50002	TONY. T	10-29-93
B	A-1	NO.3 WAS CHANGED	TONY. T	09-30-94
C	B-1	NO.9 WAS CHANGED	TONY. T	12-14-94
D	A-1	NO.1 WAS CHANGED	TONY. T	12-30-94
E	A-1	DRAWING NO. WERE CHANGED ON NO.2, NO.4, NO.7,		
	B-1	NO.8, NO.9 AND NO.10	TONY. T	09-23-96

業務部

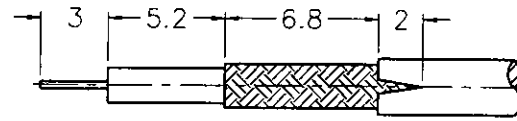

RECOMMENDED CABLE STRIPPING DIM'S

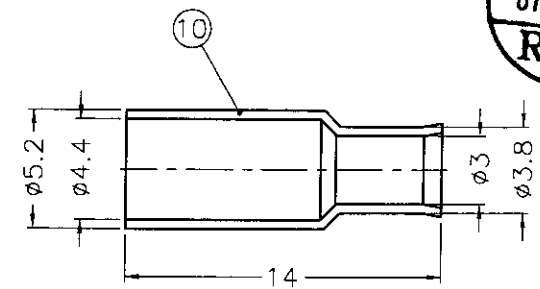
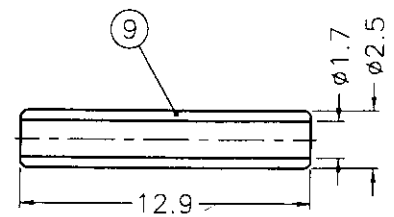
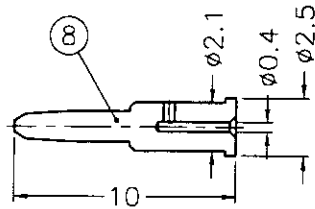
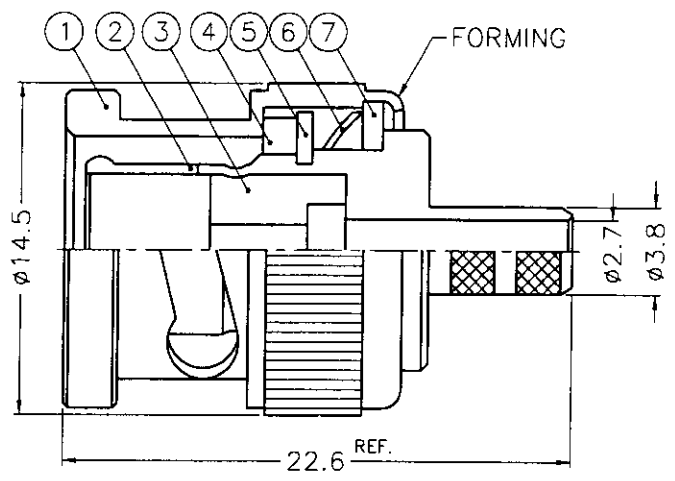

出圖
87.1.22
R&D

- NOTES: 1. PER KAI JACK SPEC. EP-SS-9700
 2. BRASS PER QQ-B-626
 3. BRASS PER QQ-B-613
 4. DELRIN 500F (B50002-3-75)
 TEFLON MIL-P-19468 (ATC B-3000-3T-75)
 5. JIS H 3260, C 3501

10	FERRULE	NOTE 5	NOTE 1	1	FR-52/44-38/3X14
9	SLEEVE	DELRIN	NATURAL	1	SL-25/17X129
8	CONTACT PIN	NOTE 2	NOTE 1	1	B3000-8-25/04
7	WASHER	NOTE 3	NOTE 1	1	WS-128/9X08
6	SPRING	SK5	NOTE 1	1	B50000-6
5	RETAINER RING	NOTE 2	NOTE 1	1	B50000-5
4	GASKET	RUBBER	RED	1	GS-115/8X15
3	INSULATOR	NOTE 4	NATURAL	1	NOTE 4
2	BODY	NOTE 2	NOTE 1	1	B50002-2-38/27
1	SHELL	NOTE 2	NOTE 1	1	B50000-1-B

DIMENSIONS ARE IN MILLIMETERS
 UNLESS OTHERWISE SPECIFIED TOLERANCES
 0.5-6 = ±0.2
 6-30 = ±0.4
 30-120 = ±0.6
 120-315 = ±1
 315-1000 = ±1.6
 1000-2000 = ±2.4

PART NO.	
APPROVED	DATE 01-13-98'
CHECKED	DATE 01-13-98'
DRAWN	DATE 01-13-98'

KAI JACK INDUSTRIAL CO., LTD. TAINAN TAIWAN R.O.C.	
TITLE	BNC CRIMP PLUG (FOR RG-179/U,187A/U)
DRAWING NO.	KJ-B1121E1-179U-75
FILE NO.	F:\DWG\B\1121E1\179U-75