

REVISIONS		
ISS	ZONE	DESCRIPTION\PER REQUEST\DATE

業務部

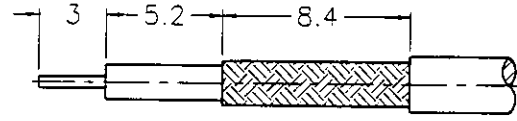

RECOMMENDED
CABLE STRIPPING DIM'S

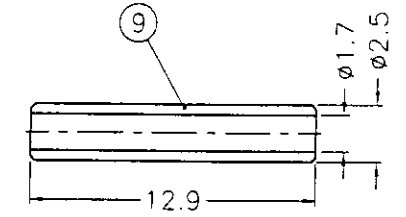
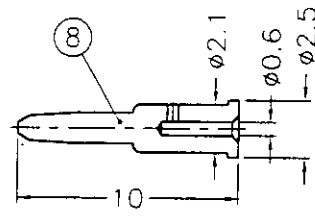
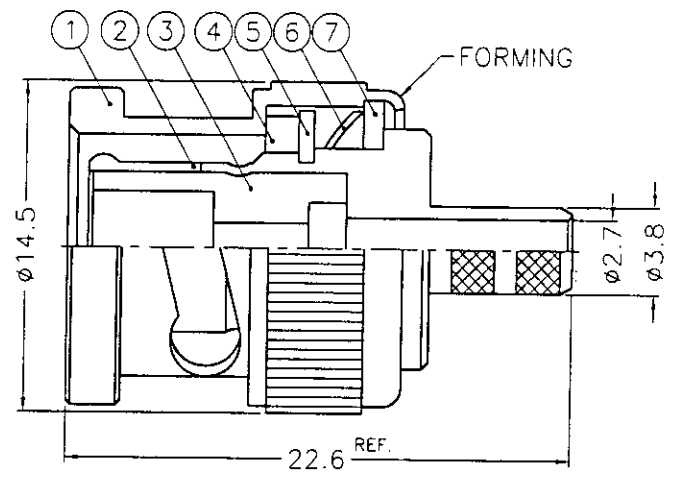

出國
87.12.17
R & D

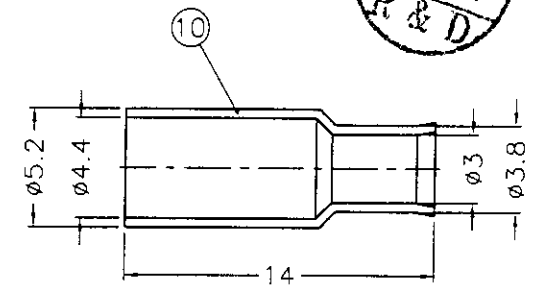

- NOTES: FINISH (PLATING THICKNESS IN MICRO-INCHES)
- 1. BRASS PER QQ-B-626
 - 2. BRASS PER QQ-B-613
 - 3. NICKEL PL. 100 MIN. THICK OVER COPPER STRIKE
 - 4. NICKEL PL. 200 MIN. THICK OVER COPPER STRIKE
 - 5. GOLD PL. 3 MIN. THICK OVER NICKEL PL. 100 MIN. THICK OVER COPPER STRIKE
 - 6. JIS H 3260, C 3501

10	FERRULE	NOTE 6	NOTE 3	1	FR-52/44-38/3X14
9	SLEEVE	DELIN	NATURAL	1	SL-25/17X129
8	CONTACT PIN	NOTE 1	NOTE 5	1	B3000-8-25/06
7	WASHER	NOTE 2	NOTE 3	1	WS-128/9X08
6	SPRING	SK5	NOTE 4	1	B50000-6
5	RETAINER RING	NOTE 1	NOTE 3	1	B50000-5
4	GASKET	RUBBER	RED	1	GS-115/8X15
3	INSULATOR	DELIN	NATURAL	1	B50002-3-50
2	BODY	NOTE 1	NOTE 3	1	B50002-2-38/27
1	SHELL	NOTE 1	NOTE 3	1	B50000-1-B

DIMENSIONS ARE IN MILLIMETERS
UNLESS OTHERWISE SPECIFIED TOLERANCES

0.5-6 = ±0.2
6-30 = ±0.4
30-120 = ±0.6
120-315 = ±1
315-1000 = ±1.6
1000-2000 = ±2.4

PART NO.	
APPROVED	DATE 12-11-98'
CHECKED	DATE 12-11-98'
DRAWN	DATE 12-11-98'

KAI JACK INDUSTRIAL CO., LTD.
TAINAN TAIWAN R.O.C.

TITLE: BNC CRIMP PLUG (FOR RG-174/U, 188A/U, 316/U)

DRAWING NO. KJ-B1121E1-ND3G-316U-50

FILE NO. F:\DWG\B\1121E1\316U-50\ND3G

F
E
D
C
B
A

F
E
D
C
B
A