

1 2 3 4 5 6 7 8

REVISIONS		
ISS	ZONE	DESCRIPTION\PER REQUEST\DATE

SALES

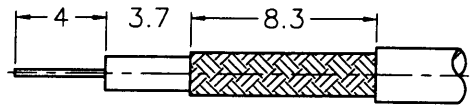

RECOMMENDED  
CABLE STRIPPING DIM'S  
(建議剝線尺寸)

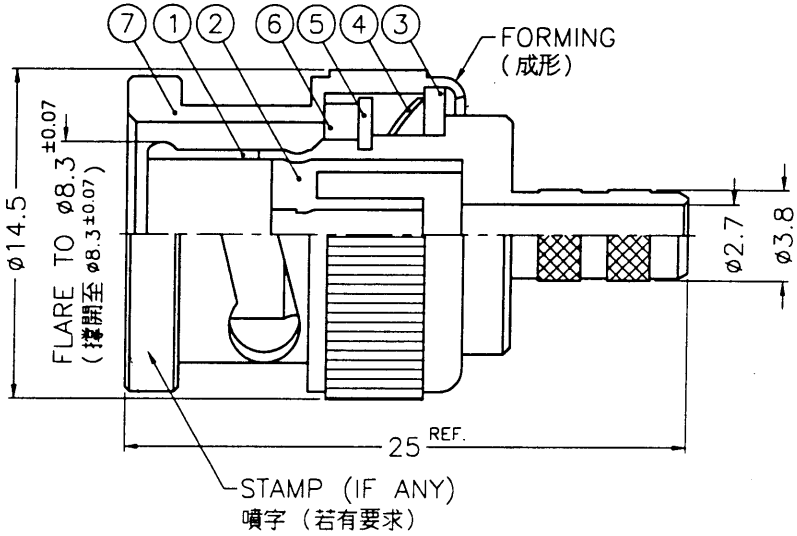
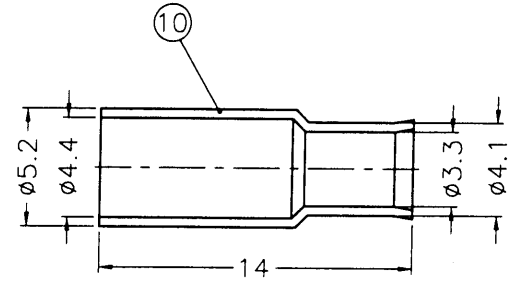
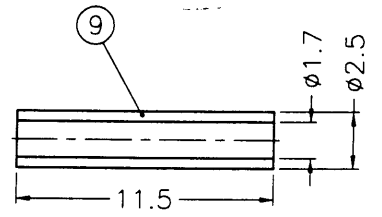
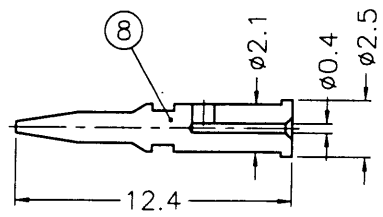
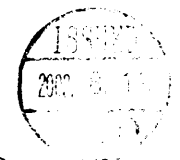

NOTES: FINISH (PLATING THICKNESS IN MICRO-INCHES)  
 1. BRASS PER QQ-B-626  
 2. BRASS PER QQ-B-613  
 3. NICKEL PL. 100 MIN. THICK OVER COPPER STRIKE  
 4. NICKEL PL. 200 MIN. THICK OVER COPPER STRIKE  
 5. GOLD PL. 3 MIN. THICK OVER NICKEL PL. 100 MIN. THICK OVER COPPER STRIKE

1. CRIMPED FERRULE  
HEX CRIMP SIZE .178"  
 2. CRIMPED CONTACT PIN  
HEX CRIMP SIZE .068"

10	FERRULE	NOTE 1	NOTE 3	1	FR-52/44-41/33 X14
9	SLEEVE	DELTRIN	NATURAL	1	SL-25/17X115
8	CONTACT PIN	NOTE 1	NOTE 5	1	B50000-8-25/04
7	SHELL	NOTE 1	NOTE 3	1	B50000-1-B
6	GASKET	RUBBER	RED	1	GS-115/8X15
5	RETAINER RING	NOTE 1	NOTE 3	1	B50000-5
4	SPRING	SK5	NOTE 4	1	B50000-6
3	WASHER	NOTE 2	NOTE 3	1	WS-128/9X08
2	INSULATOR	DELTRIN	NATURAL	1	B50000-3-75-A
1	BODY	NOTE 1	NOTE 3	1	B50000-2-38/27
NO.	DESCRIPTION	MATERIAL	FINISH	Q'TY	DRAWING NO.

DIMENSIONS ARE IN MILLIMETERS		PART NO.	
UNLESS OTHERWISE SPECIFIED TOLERANCES		APPROVED	DATE
0.5-6 = ±0.2	6-30 = ±0.4	<i>Mark C</i>	08-12-02'
30-120 = ±0.6	120-315 = ±1	CHECKED	DATE
315-1000 = ±1.6	1000-2000 = ±2.4	<i>Karl J.</i>	08-12-02'
		DRAWN	DATE
		<i>Angela W</i>	08-12-02'
SCALE	3/1	ISSUE	A2
FILE NO.	F:\DWG\B\1121E2\15C2C-75\ND3G		

**Amphenol - Kai Jack**  
TAINAN TAIWAN

TITLE BNC CRIMP PLUG  
(FOR 1.5C-2V CABLE)

DRAWING NO. KJ-B1121E2-ND3G-1.5C2V-75

ITEM NO. 011121AAM10ND7F

1 2 3 4 5 6 7 8

7RD-DR 15198 8