

REVISIONS			
ISS	ZONE	DESCRIPTION	PER REQUEST DATE

SALES

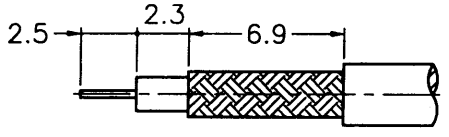

RECOMMENDED
CABLE STRIPPING DIM'S
(建議剝線尺寸)

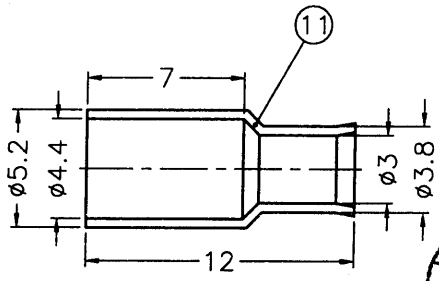
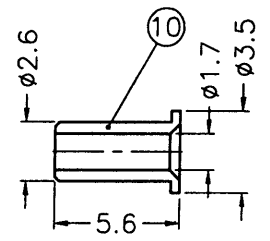
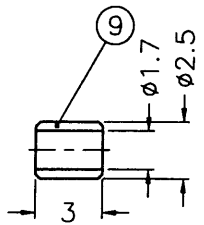
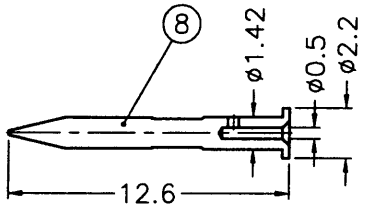
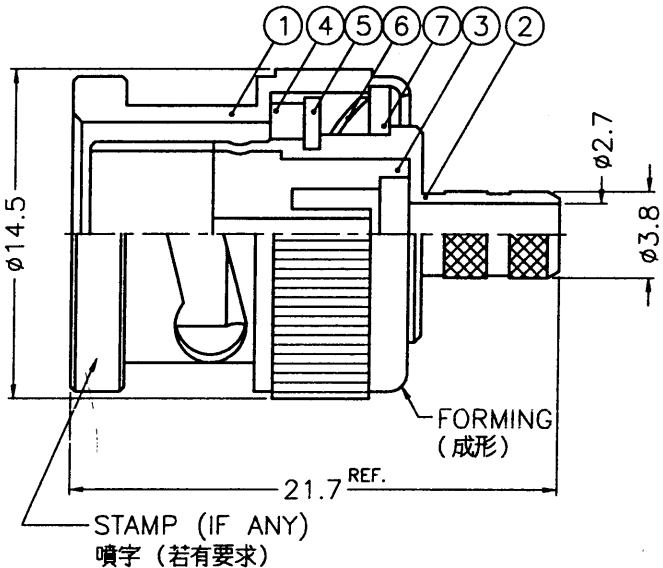

1. CRIMPED FERRULE
HEX CRIMP SIZE .178"

ISSUED
2002.4.17
R&D

- NOTES: FINISH (PLATING THICKNESS IN MICRO-INCHES)
1. BRASS PER QQ-B-626
 2. BRASS PER QQ-B-613
 3. NICKEL PL. 100 MIN. THICK OVER COPPER STRIKE
 4. NICKEL PL. 200 MIN. THICK OVER COPPER STRIKE
 5. GOLD PL. 3 MIN. THICK OVER NICKEL PL. 100 MIN. THICK OVER COPPER STRIKE

NO.	DESCRIPTION	MATERIAL	FINISH	Q'TY	DRAWING NO.
11	FERRULE	NOTE 1	NOTE 3	1	FR-52/44-38/3X12
10	SPACER	NOTE 1	NOTE 3	1	SP-35F/17X56
9	SLEEVE	DELTRIN	NATURAL	1	SL-25/17X3
8	CONTACT PIN	NOTE 1	NOTE 5	1	B50004-8-22/05
7	WASHER	NOTE 2	NOTE 3	1	WS-128/9X08
6	SPRING	SK5	NOTE 4	1	B50000-6
5	RETAINER RING	NOTE 1	NOTE 3	1	B50000-5
4	GASKET	RUBBER	RED	1	GS-115/8X15
3	INSULATOR	TPX	NATURAL	1	B50004-3X-75
2	BODY	NOTE 1	NOTE 3	1	B50007-2-38/27
1	SHELL	NOTE 1	NOTE 3	1	B50000-1-B

DIMENSIONS ARE IN MILLIMETERS				PART NO.	
UNLESS OTHERWISE SPECIFIED TOLERANCES				APPROVED	DATE
0.5-6	= ±0.2	A. K. C. 04-03-02'			
6-30	= ±0.4	CHECKED	Karl J. 04-03-02'		
30-120	= ±0.6	DRAWN	Angela W. 04-03-02'		
120-315	= ±1	FILE NO. F:\DWG\B\1121E9\179U-75\NTPX3G			
315-1000	= ±1.6				
1000-2000	= ±2.4				

Amphenol - Kai Jack	
TAINAN TAIWAN	
TITLE	BNC CRIMP PLUG (FOR RG-179/U, 187A/U CABLE)
DRAWING NO.	KJ-B1121E9-NTPX3G-179U-75
ITEM NO.	011121ACF19NY7F

F
E
D
C
B
A

F
E
D
C
B
A