

REVISIONS		
ISS	ZONE	DESCRIPTION \ APPROVED \ DATE

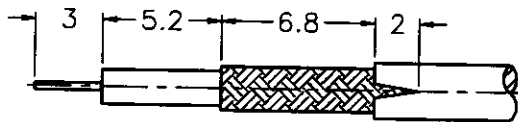

RECOMMENDED  
CABLE STRIPPING DIM'S

業務部

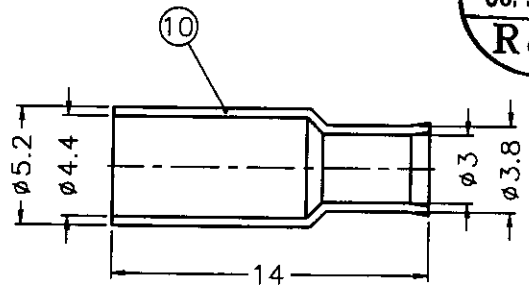
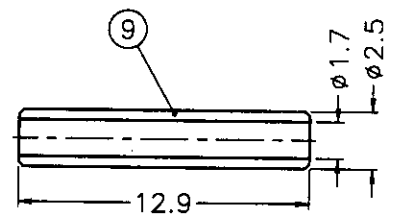
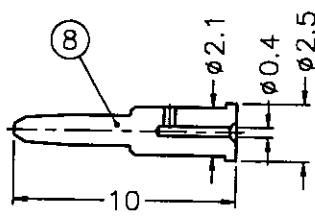
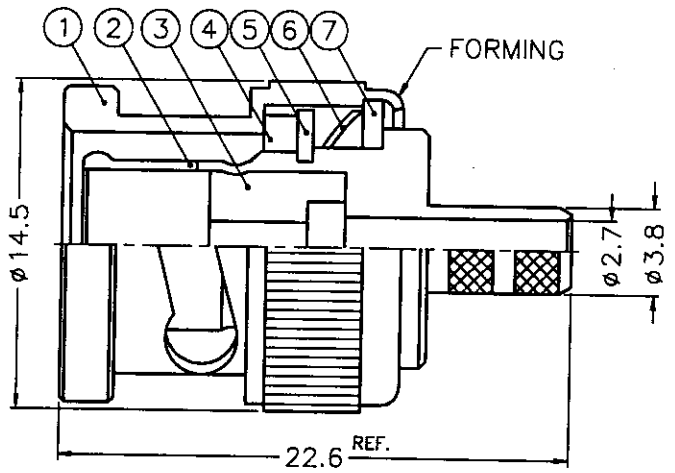

出圖  
86.3.26  
R&D

- NOTES: FINISH (PLATING THICKNESS IN MICRO-INCHES)
- BRASS PER QQ-B-826, ALLOY 360, 1/2 H
  - BRASS PER QQ-B-613, COMP 260, HARD TEMP
  - NICKEL PL. 100 MIN. OVER COPPER PL. 50 MIN.  
SILVER PL. 80 MIN. OVER COPPER PL. 50 MIN.
  - GOLD PL. MIN. OVER NICKEL PL. 50 MIN.  
OVER COPPER PL. 50 MIN.  
SILVER PL. 100 MIN. OVER NICKEL PL. 50 MIN.  
OVER COPPER PL. 50 MIN.
  - DELTRIN 500F (B50002-3-75)  
TEFLON MIL-P-19468 (ATC B-3000-3T-75)

10	FERRULE	NOTE 1	NOTE 3	1	FR-52/44-38/3X14
9	SLEEVE	DELTRIN	NATURAL	1	SL-25/17X129
8	CONTACT PIN	NOTE 1	NOTE 4	1	B3000-8-25/04
7	WASHER	NOTE 2	NOTE 3	1	WS-128/9X08
6	SPRING	SK5	NOTE 3	1	B50000-6
5	RETAINER RING	NOTE 1	NOTE 3	1	B50000-5
4	GASKET	RUBBER	RED	1	GS-115/8X15
3	INSULATOR	NOTE 5	NATURAL	1	NOTE 5
2	BODY	NOTE 1	NOTE 3	1	B50002-2-38/27
1	SHELL	DIECAST	NOTE 3	1	B50000Z-1
NO.	DESCRIPTION	MATERIAL	FINISH	Q'TY	DRAWING NO.

DIMENSIONS ARE IN MILLIMETERS  
UNLESS OTHERWISE SPECIFIED TOLERANCES

0.5-6	= ±0.2
6-30	= ±0.4
30-120	= ±0.6
120-315	= ±1
315-1000	= ±1.6
1000-2000	= ±2.4

PART NO.	
APPROVED	DATE 03-20-97'
CHECKED	DATE 03-20-97'
DRAWN	DATE 03-20-97'

KAI JACK INDUSTRIAL CO., LTD. TAINAN TAIWAN R.O.C.	
TITLE	BNC CRIMP PLUG (FOR RG-179/U,187A/U)
DRAWING NO.	KJ-B1121F1-179U-75
FILE NO.	F:\DWG\B\1121F1\179U-75