

REVISIONS		
ISS	ZONE	DESCRIPTION\APPROVED\DATE

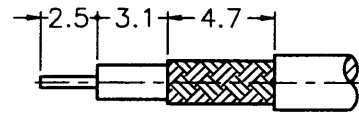

RECOMMENDED
CABLE STRIPPING DIM'S

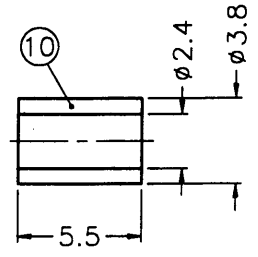
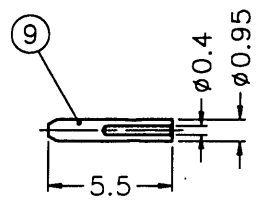
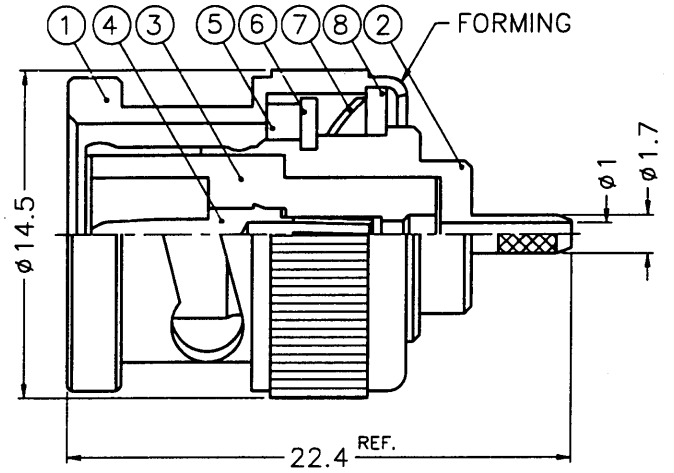

- NOTES: FINISH (PLATING THICKNESS IN MICRO-INCHES)
- BRASS PER QQ-B-626, ALLOY 360, 1/2 H
 - BRASS PER QQ-B-613, COMP 260, HARD TEMP
 - NICKEL PL. 100 MIN. OVER COPPER PL. 50 MIN.
SILVER PL. 80 MIN. OVER COPPER PL. 50 MIN.
 - PHOSPHOR BRONZE PER QQ-B-750, COMP A, 1/2 H
 - GOLD PL. MIN. OVER NICKEL PL. 50 MIN.
OVER COPPER PL. 50 MIN.
SILVER PL. 100 MIN. OVER NICKEL PL. 50 MIN.
OVER COPPER PL. 50 MIN.
 - DELTRIN 500F (B1121G1-3-50)
TEFLON MIL-P-19468 (B1121G1-3T-50)

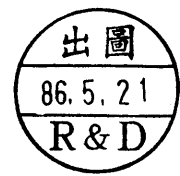

10	FERRULE	COPPER	NOTE 3	1	FR-38/24X55C
9	CONTACT PIN	NOTE 1	NOTE 5	1	B50003-9-0.4
8	WASHER	NOTE 2	NOTE 3	1	WS-128/9X08
7	SPRING	SK5	NOTE 3	1	B50000-6
6	RETAINER RING	NOTE 1	NOTE 3	1	B50000-5
5	GASKET	RUBBER	RED	1	GS-115/8X15
4	CONTACT PIN	NOTE 4	NOTE 5	1	B1121G1-4-1.05
3	INSULATOR	NOTE 6	NATURAL	1	NOTE 6
2	BODY	NOTE 1	NOTE 3	1	B1121G1-2-17/ 1
1	SHELL	NOTE 1	NOTE 3	1	B50000-1-B
NO.	DESCRIPTION	MATERIAL	FINISH	Q'TY	DRAWING NO.

DIMENSIONS ARE IN MILLIMETERS				PART NO.	
UNLESS OTHERWISE SPECIFIED TOLERANCES				APPROVED <i>Tommy E</i> DATE 05-20-97'	
0.5-6	= ±0.2			CHECKED <i>Mark C</i> DATE 05-20-97'	
6-30	= ±0.4			DRAWN <i>Andy C</i> DATE 05-20-97'	
30-120	= ±0.6				
120-315	= ±1				
315-1000	= ±1.6				
1000-2000	= ±2.4				
SCALE	3/1	ISSUE	A		

<p>KAI JACK INDUSTRIAL CO., LTD. TAINAN TAIWAN R.O.C.</p>		TITLE	BNC CRIMP PLUG (FOR RG-178B/U, 196A/U)
		DRAWING NO.	KJ-B1121G1-196AU-50
		FILE NO.	F:\DWG\B\1121G1\196AU-50

F
E
D
C
B
A

F
E
D
C
B
A