

1			2			3			4			5			6			7			8		
REVISIONS																							
ISS	ZONE	DESCRIPTION\PER REQUEST\DATE																					

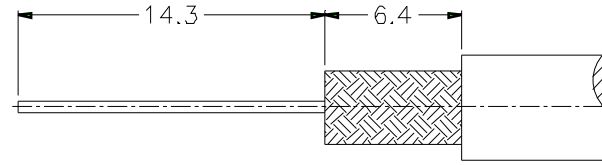

RECOMMENDED
CABLE STRIPPING DIM'S

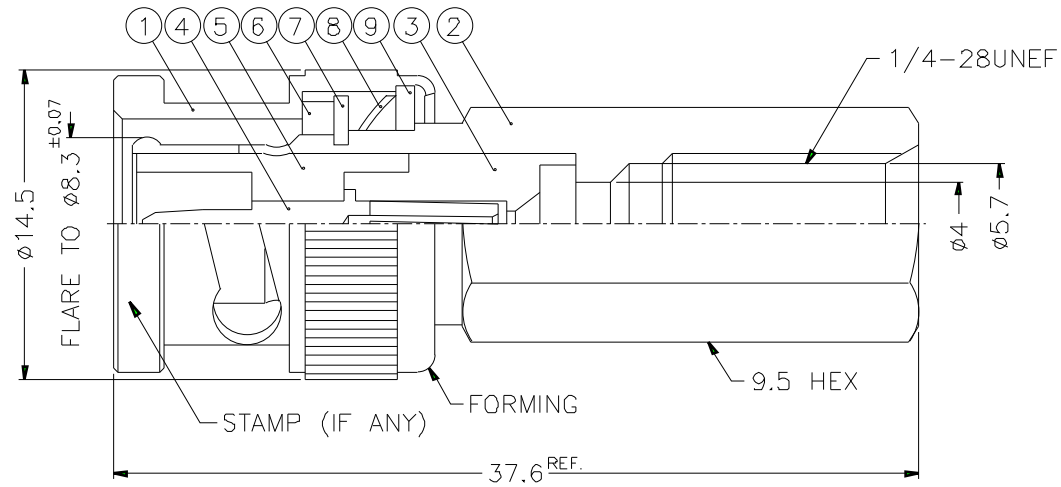

NOTES: FINISH (PLATING THICKNESS IN MICRO-INCHES)

1. BRASS PER QQ-B-626
2. BRASS PER QQ-B-613
3. NICKEL PL. 100 MIN. THICK OVER COPPER STRIKE
4. NICKEL PL. 200 MIN. THICK OVER COPPER STRIKE
5. GOLD PL. 3 MIN. THICK OVER NICKEL PL. 100 MIN. THICK OVER COPPER STRIKE

9	WASHER	NOTE 2	NOTE 3	1	WS-128/9X08
8	SPRING	SK5	NOTE 4	1	B50000-6
7	RETAINER RING	NOTE 1	NOTE 3	1	B50000-5
6	GASKET	RUBBER	RED	1	CS-115/8X15
5	INSULATOR	DELTRIN	NATURAL	1	B5100-5-50
4	CONTACT PIN	NOTE 1	NOTE 5	1	B5100-4-21/076
3	INSULATOR	DELTRIN	NATURAL	1	B5100-3-50
2	HEX BODY	NOTE 1	NOTE 3	1	B5100-2-57/4
1	SHELL	NOTE 1	NOTE 3	1	B50000-1-B

DIMENSIONS ARE IN MILLIMETERS
UNLESS OTHERWISE SPECIFIED TOLERANCES

0.5-6	= ±0.2
6-30	= ±0.4
30-120	= ±0.6
120-315	= ±1
315-1000	= ±1.6
1000-2000	= ±2.4

PART NO.	B1131A1-ND3G-3-50	
APPROVED	DATE	10-11-01'
CHECKED	DATE	10-11-01'
DRAWN	DATE	10-11-01'

Amphenol	
TITLE	BNC TWIST-ON PLUG
DRAWING NO.	KJ-B1131A1-ND3G-59U-50
ITEM NO.	

NO.	DESCRIPTION	MATERIAL	FINISH	Q'TY	DRAWING NO.	SCALE	3/1	ISSUE	A	FILE NO.
-----	-------------	----------	--------	------	-------------	-------	-----	-------	---	----------

1 2 3 4 5 6 7 8