

REVISIONS		
ISS	ZONE	DESCRIPTION\PER REQUEST\DATE

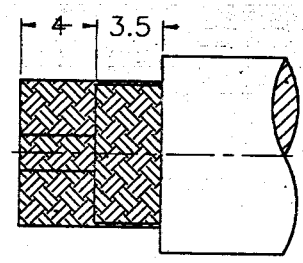

THIS DRAWING HAS APPROVED BY:

CUSTOMER SIGNATURE
DATE: _____

RECOMMENDED
 CABLE STRIPPING DIM'S
 (建議剝線尺寸)

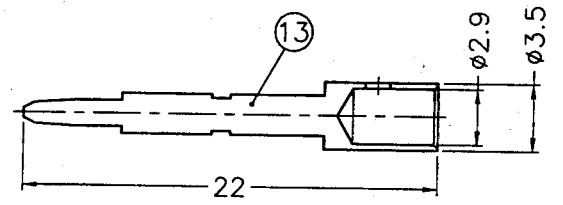
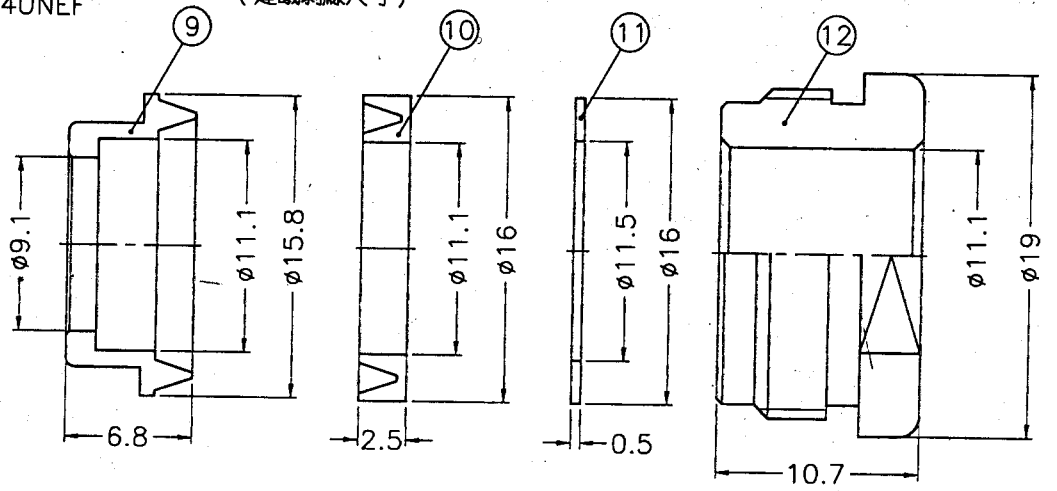
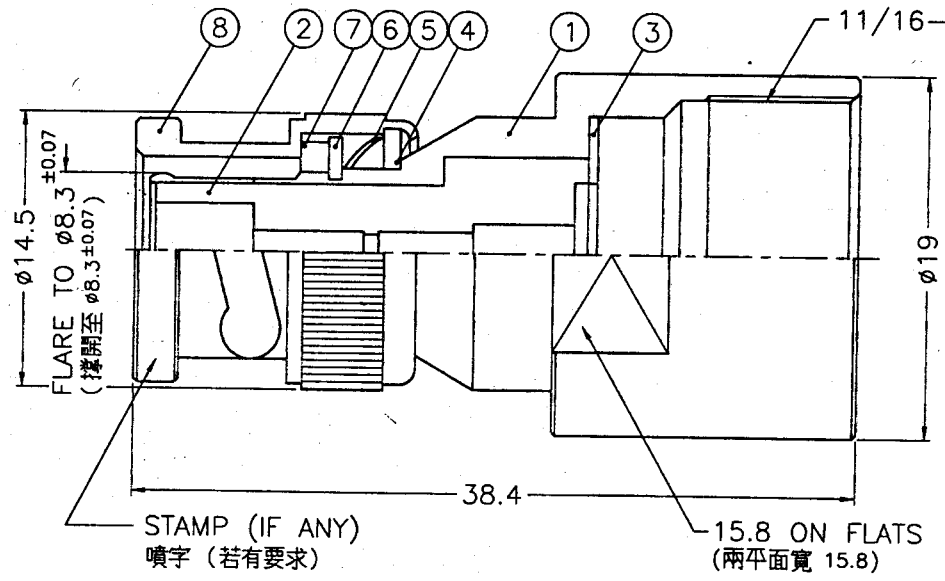

NOTES: FINISH (PLATING THICKNESS IN MICRO-INCHES)
 1. BRASS PER QQ-B-626
 2. BRASS PER QQ-B-613
 3. NICKEL PL. 100 MIN. OVER COPPER PL. 50 MIN.
 4. NICKEL PL. 200 MIN. OVER COPPER PL. 50 MIN.
 5. GOLD PL. 3 MIN. OVER NICKEL PL. 50 MIN. OVER COPPER PL. 50 MIN.
 6. TEFLON MIL-P-19468

13	CONTACT PIN	NOTE 1	NOTE 5	1	B5201-13-35/29
12	NUT	NOTE 1	NOTE 3	1	B5201-12-19/111
11	WASHER	NOTE 2	NOTE 3	1	WS-16/115X05
10	GASKET	SILICONE	RED	1	B5201-10
9	BRAID CLAMP	NOTE 1	NOTE 3	1	B5201-9-111/91
8	SHELL	NOTE 1	NOTE 3	1	B50000-1-B
7	GASKET	RUBBER	RED	1	GS-115/8X15
6	RETAINER RING	NOTE 1	NOTE 3	1	B50000-5
5	SPRING	SK5	NOTE 4	1	B50000-6
4	WASHER	NOTE 2	NOTE 3	1	WS-128/9X08
3	WASHER	NOTE 2	NOTE 3	1	WS-145/75X05
2	INSULATOR	NOTE 6	NATURAL	1	B5201-3T-50
1	BODY	NOTE 1	NOTE 3	1	B5201-2
NO.	DESCRIPTION	MATERIAL	FINISH	Q'TY	DRAWING NO.

DIMENSIONS ARE IN MILLIMETERS
 UNLESS OTHERWISE SPECIFIED TOLERANCES
 0.5-6 = ±0.2
 6-30 = ±0.4
 30-120 = ±0.6
 120-315 = ±1
 315-1000 = ±1.6
 1000-2000 = ±2.4

PART NO.	
APPROVED	DATE 09-04-03'
CHECKED	DATE 09-04-03'
DRAWN	DATE 09-04-03'

Amphenol
 Danbury, CT, USA - Tainan, Taiwan - Shenzhen, China

TITLE
BNC CLAMP PLUG

DRAWING NO.
B1141A2-NT3G-9913-50

ITEM NO.
011141AAE93NA5F