

1 2 3 4 5 6 7 8

REVISIONS		
ISS	ZONE	DESCRIPTION\PER REQUEST\DATE

業務部

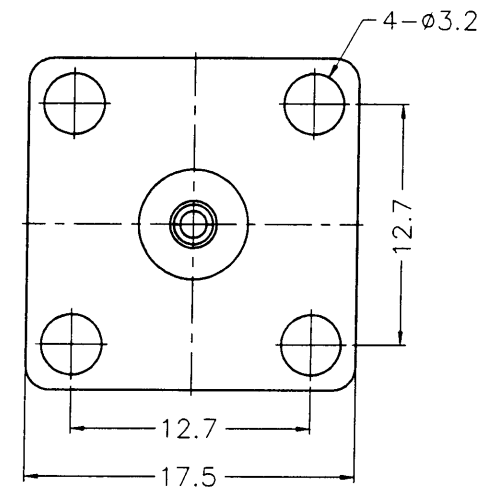
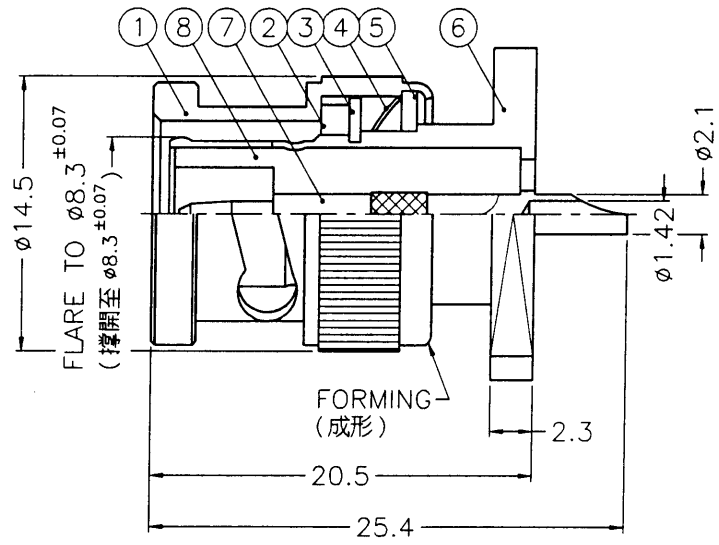

NOTES: FINISH (PLATING THICKNESS IN MICRO-INCHES)
 1. BRASS PER QQ-B-626
 2. BRASS PER QQ-B-613
 3. NICKEL PL. 100 MIN. THICK OVER COPPER STRIKE
 4. NICKEL PL. 200 MIN. THICK OVER COPPER STRIKE
 5. GOLD PL. 3 MIN. THICK OVER NICKEL PL. 100 MIN. THICK OVER COPPER STRIKE
 6. TEFLON MIL-P-19468

出圖
89.4.14
設計部

NO.	DESCRIPTION	MATERIAL	FINISH	Q'TY	DRAWING NO.	SCALE	2.5/1	ISSUE	A	PART NO.	TITLE
8	INSULATOR	NOTE 6	NATURAL	1	B1551A1-8T-50	DIMENSIONS ARE IN MILLIMETERS				Amphenol - Kai Jack TAINAN TAIWAN BNC PANEL PLUG KJ-B1551A1-NT3G-50 F:\DWG\B\1551A1\50\NT3G	
7	CONTACT PIN	NOTE 1	NOTE 5	1	B1551A1-7	UNLESS OTHERWISE SPECIFIED TOLERANCES					
6	BODY	NOTE 1	NOTE 3	1	B1551A1-6	0.5-6 = ±0.2					
5	WASHER	NOTE 2	NOTE 3	1	WS-128/9X08	6-30 = ±0.4					
4	SPRING	SK5	NOTE 4	1	B50000-6	30-120 = ±0.6					
3	RETAINER RING	NOTE 1	NOTE 3	1	B50000-5	120-315 = ±1					
2	GASKET	RUBBER	RED	1	GS-115/8X15	315-1000 = ±1.6					
1	SHELL	NOTE 1	NOTE 3	1	B50000-1-B	1000-2000 = ±2.4					
APPROVED: <i>A. K. C.</i> DATE: 04-11-00' CHECKED: <i>Jacky</i> DATE: 04-11-00' DRAWN: <i>Aola</i> DATE: 04-11-00'											

974