

1 2 3 4 5 6 7 8

業務部

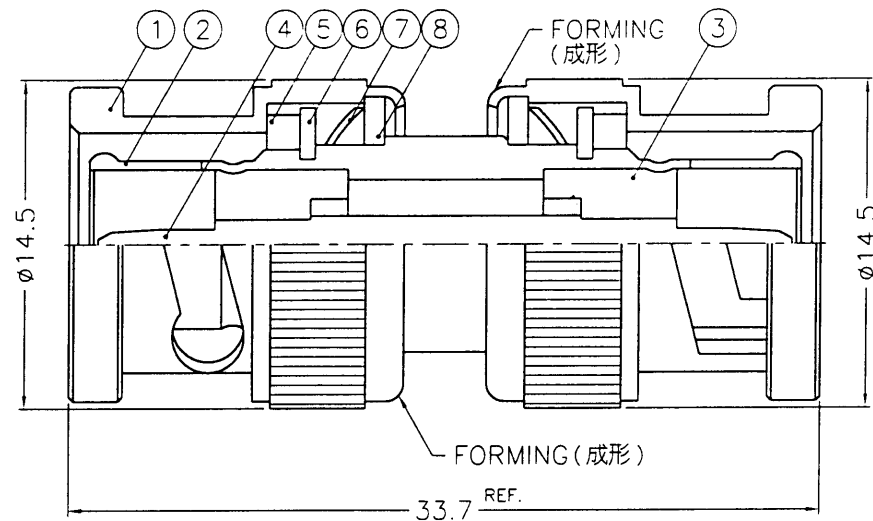

NOTES: FINISH (PLATING THICKNESS IN MICRO-INCHES)

- 1. BRASS PER QQ-B-626
- 2. BRASS PER QQ-B-613
- 3. NICKEL PL. 100 MIN. THICK OVER COPPER STRIKE
- 4. NICKEL PL. 200 MIN. THICK OVER COPPER STRIKE
- 5. GOLD PL. 3 MIN. THICK OVER NICKEL PL. 100 MIN. THICK OVER COPPER STRIKE



8	WASHER	NOTE 2	NOTE 3	2	WS-12B/9X08	DIMENSIONS ARE IN MILLIMETERS UNLESS OTHERWISE SPECIFIED TOLERANCES 0.5-6 = ±0.2 6-30 = ±0.4 30-120 = ±0.6 120-315 = ±1 315-1000 = ±1.6 1000-2000 = ±2.4	PART NO.		KAI JACK INDUSTRIAL CO., LTD. TAINAN TAIWAN R.O.C.	TITLE		
7	SPRING	SK5	NOTE 4	2	B50000-6		APPROVED	DATE			BNC MALE TO BNC MALE ADAPTOR	
6	RETAINER RING	NOTE 1	NOTE 3	2	B50000-5		Mark C Mark C	08-23-99'				
5	GASKET	RUBBER	RED	2	GS-115/8X15			CHECKED				DATE
4	CONTACT PIN	NOTE 1	NOTE 5	1	B5900-5		Betty L	08-23-99'				
3	INSULATOR	DELIN	NATURAL	2	B50002-3-75			DRAWN				DATE
2	BODY	NOTE 1	NOTE 3	1	B5900-2		08-23-99'	DRAWING NO.				KJ-B2071A2-ND3G-75
1	SHELL	NOTE 1	NOTE 3	2	B50000-1-B		08-23-99'	FILE NO.				F:\DWG\B\2071A2\75\ND3G
NO.	DESCRIPTION	MATERIAL	FINISH	Q'TY	DRAWING NO.	SCALE	3/1	ISSUE	A			

1 2 3 4 5 6 7 8 8/25/99