

1 2 3 4 5 6 7 8

REVISIONS			
ISS	ZONE	DESCRIPTION	APPROVED \ DATE

業務部

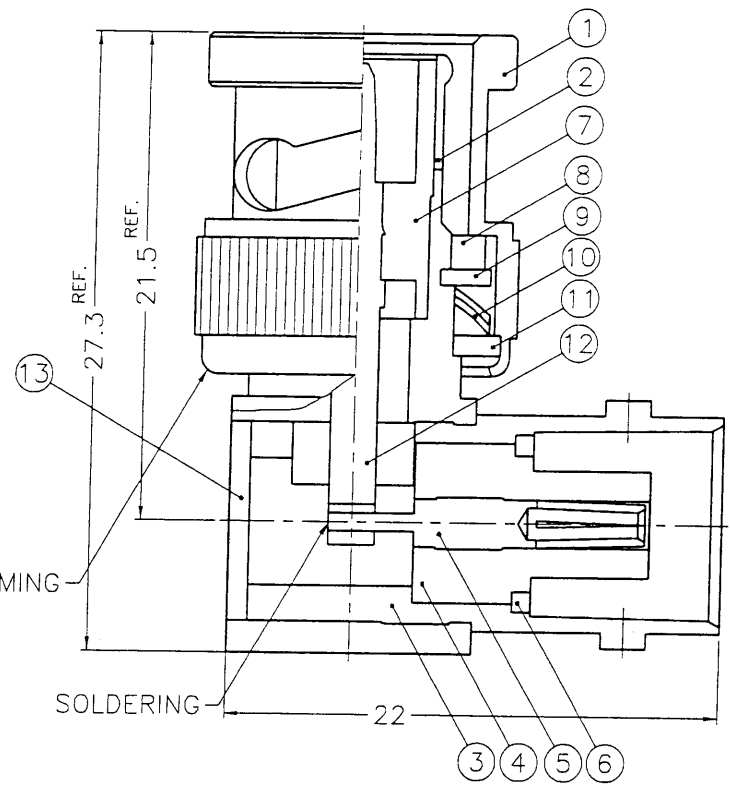

NOTES: FINISH (PLATING THICKNESS IN MICRO-INCHES)
 1. BRASS PER QQ-B-626
 2. BRASS PER QQ-B-613
 3. NICKEL PL. 100 MIN. THICK OVER COPPER STRIKE
 4. NICKEL PL. 200 MIN. THICK OVER COPPER STRIKE
 5. PHOSPHOR BRONZE PER QQ-B-750
 6. GOLD PL. 3 MIN. THICK OVER NICKEL PL. 100 MIN. THICK OVER COPPER STRIKE

13	COVER	NOTE 2	NOTE 3	1	CV-895X07-T
12	CONTACT PIN	NOTE 1	NOTE 6	1	B5091-6-50
11	WASHER	NOTE 2	NOTE 3	1	WS-128/9X08
10	SPRING	SK5	NOTE 4	2	B50000-6
9	RETAINER RING	NOTE 1	NOTE 3	1	B50000-5
8	GASKET	RUBBER	RED	1	GS-115/BX15
7	INSULATOR	DELTRIN	NATURAL	1	B50002-3-50
6	LOCK RING	NOTE 2	NOTE 3	1	B7700-4
5	CONTACT PIN	NOTE 5	NOTE 6	1	B5990-5
4	INSULATOR	DELTRIN	NATURAL	1	B5990-4-50
3	BODY	NOTE 1	NOTE 3	1	B5990-3
2	HOUSING	NOTE 1	NOTE 3	1	B7996-2
1	SHELL	NOTE 1	NOTE 3	1	B50000-1-B
NO.	DESCRIPTION	MATERIAL	FINISH	Q'TY	DRAWING NO.

DIMENSIONS ARE IN MILLIMETERS
 UNLESS OTHERWISE SPECIFIED TOLERANCES
 0.5-6 = ±0.2
 6-30 = ±0.4
 30-120 = ±0.6
 120-315 = ±1
 315-1000 = ±1.6
 1000-2000 = ±2.4

PART NO.	
APPROVED	Mark C DATE 10-06-98'
CHECKED	Mark C DATE 10-06-98'
DRAWN	Betty DATE 10-06-98'

<p>KAI JACK INDUSTRIAL CO., LTD. TAINAN TAIWAN R.O.C.</p>	
TITLE	BNC MALE TO FEMALE R/A ADAPTOR
DRAWING NO.	KJ-B5072A1-ND3G-50
FILE NO.	F:\DWG\B\5072A1\50\ND3G

出圖
87.10.14
R&D

ADT-20365