

REVISIONS			
ISS	ZONE	DESCRIPTION\PER REQUEST\DATE	
B	A-1	NO.1 WAS CHANGED\RD-DM89061401H\06-14-00'	

業務部

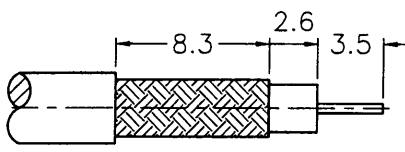

RECOMMENDED CABLE STRIPPING DIM'S (建議剝線尺寸)

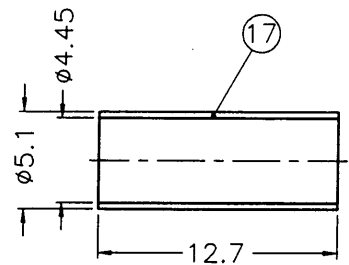

- NOTES: FINISH (PLATING THICKNESS IN MICRO-INCHES)
1. BRASS PER QQ-B-626
 2. BRASS PER QQ-B-613
 3. NICKEL PL. 100 MIN. THICK OVER COPPER STRIKE
 4. NICKEL PL. 200 MIN. THICK OVER COPPER STRIKE
 5. PHOSPHOR BRONZE PER QQ-B-750
 6. GOLD PL. 3 MIN. THICK OVER NICKEL PL. 100 MIN. THICK OVER COPPER STRIKE
 7. TEFLON MIL-P-19468
 8. JIS H3250, C 2700

SOLDERING (BY USER)
(由客戶銲接)

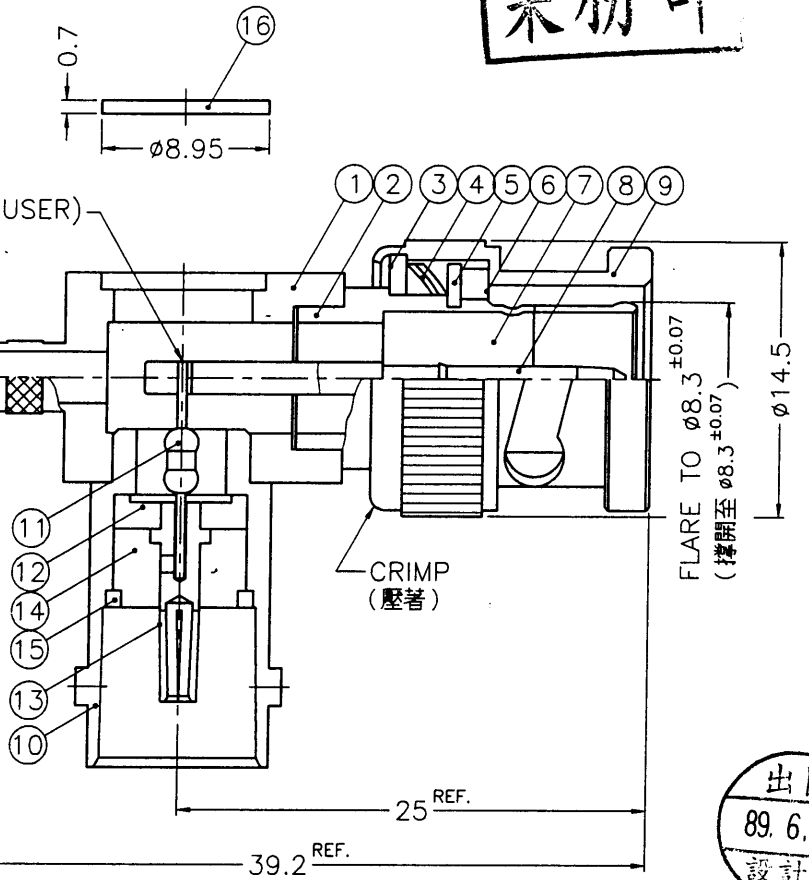

出圖
89.6.15
設計部

1. CRIMPED FERRULE
HEX CRIMP SIZE .178"

17	FERRULE	NOTE 8	NOTE 3	1	FR-51/445X127
16	COVER	NOTE 2	NOTE 3	1	CV-895X07-T
15	LOCK RING	NOTE 1	NOTE 3	1	B5071A1-4
14	INSULATOR	NOTE 7	NATURAL	1	B7200-2T-75
13	CONTACT PIN	NOTE 5	NOTE 6	1	B6141A1-3-21/06
12	INSULATOR	NOTE 7	NATURAL	1	B7200-4T-50
11	RESISTOR	75R	0.125W	1	RS-75R-0.125W-1%
10	BODY	NOTE 1	NOTE 3	1	S38-4082-75-13
9	SHELL	NOTE 1	NOTE 3	1	B50000-1-B
8	CONTACT PIN	NOTE 1	NOTE 6	1	B5173A1-8
7	INSULATOR	NOTE 7	NATURAL	1	B1112A6-4T-75
6	GASKET	RUBBER	RED	1	GS-115/8X15
5	RETAINER RING	NOTE 1	NOTE 3	1	B50000-5
4	SPRING	SK5	NOTE 4	2	B50000-6
3	WASHER	NOTE 2	NOTE 3	1	WS-128/9X08
2	BODY	NOTE 1	NOTE 3	1	B1112A6-2
1	HOUSING	NOTE 1	NOTE 3	1	B5173A1-1-B
NO.	DESCRIPTION	MATERIAL	FINISH	Q'TY	DRAWING NO.

DIMENSIONS ARE IN MILLIMETERS
UNLESS OTHERWISE SPECIFIED TOLERANCES
0.5-6 = ±0.2
6-30 = ±0.4
30-120 = ±0.6
120-315 = ±1
315-1000 = ±1.6
1000-2000 = ±2.4

PART NO.	
APPROVED	DATE 06-14-00'
CHECKED	DATE 06-14-00'
DRAWN	DATE 06-14-00'

Amphenol - Kai Jack	
TAINAN TAIWAN	
TITLE	BNC R/A CRIMP ADAPTOR (FOR 2.5C-2V CABLE)
DRAWING NO.	KJ-B5173A1-NT3G-2.5C2V-75
FILE NO.	F:\DWG\B\5173A1\25C2V-75\NT3G

A