

1 2 3 4 5 6 7 8

REVISIONS			
ISS	ZONE	DESCRIPTION\PER REQUEST\DATE	
A2	C-4	NO.2'S DESIGN WAS CHANGED\N/A\09-09-02'	
A3	A-1	NO.3'S METERIAL WAS CHANGED\N/A\10-01-02'	

REMARK: 1.CHAIN AND PANEL MUST BE TURNING RELATIVE AFTER FLARING (撐開後, CHAIN和PANEL須仍可自由轉動)  
 2.MUST WITHSTAND 3 psi FOR 1 MINUTE WITHOUT LEAKAGE. (須能承受壓力 3psi/1min)

SALES

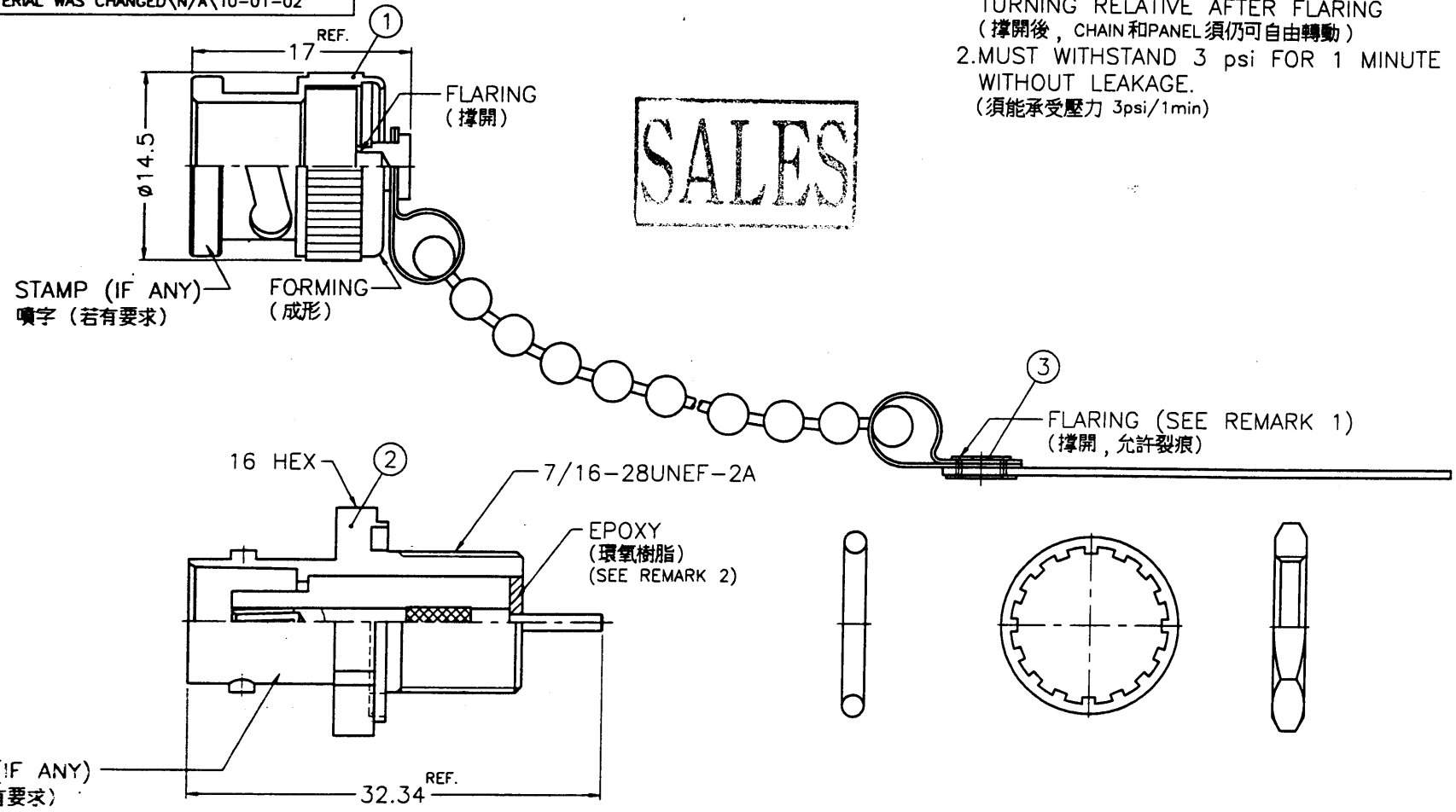

NOTES: FINISH (PLATING THICKNESS IN MICRO-INCHES)  
 1. OUT SOURCE  
 2. NICKEL FLASH

DIMENSIONS ARE IN MILLIMETERS				PART NO.	
UNLESS OTHERWISE SPECIFIED TOLERANCES				APPROVED	DATE
0.5-6 = ±0.2				<i>[Signature]</i>	10-01-02'
6-30 = ±0.4				CHECKED	DATE
30-120 = ±0.6				<i>[Signature]</i>	10-01-02'
120-315 = ±1				DRAWN	DATE
315-1000 = ±1.6				<i>[Signature]</i>	10-01-02'
1000-2000 = ±2.4					
SCALE	2/1	ISSUE	A3	FILE NO.	F:\DWG\B\6001A1\001\50\NT30G-A2

<b>Amphenol - Kai Jack</b>	
TAINAN TAIWAN	
TITLE	BNC FEMALE CONNECTOR WITH CAP
DRAWING NO.	KJ-B6001A1-001-NT30G-50
ITEM NO.	016001AAA00NC5F

NO.	DESCRIPTION	MATERIAL	FINISH	Q'TY	DRAWING NO.
3	RVT	SS41	NOTE 1,2	1	RV00AAC01A
2	CONNECTOR			1	B6351A3-002-NT30G-50
1	CONNECTOR			1	B1005A1-006-N

7RD DR 15618 8

1 2 3 4 5 6 7 8

REVISIONS		
ISS	ZONE	DESCRIPTION\PER REQUEST\DATE
A2	D-3	DESIGN WAS CHANGED\N/A\09-09-02'

REMARK: MUST WITHSTAND 3 psi FOR 1 MINUTE WITHOUT LEAKAGE.  
(須能承受壓力 3psi/1min)

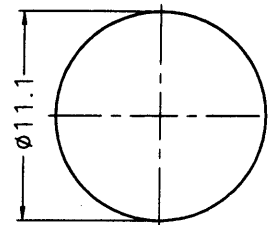

**SALES**

RECOMMENDED MOUNTING HOLE  
(建議架設孔)

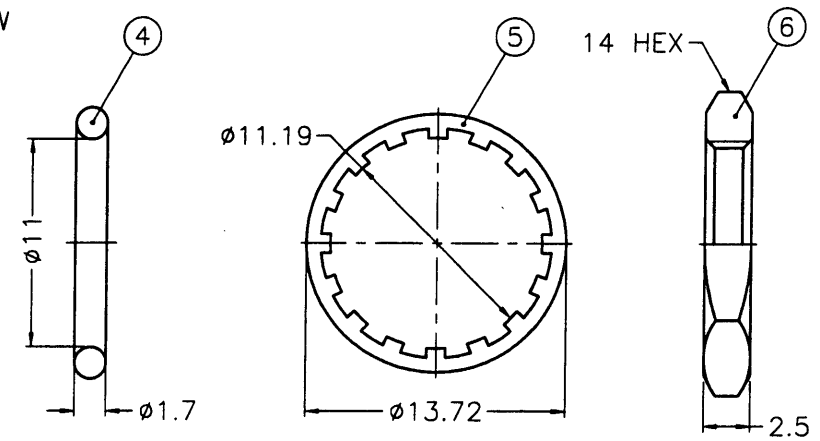
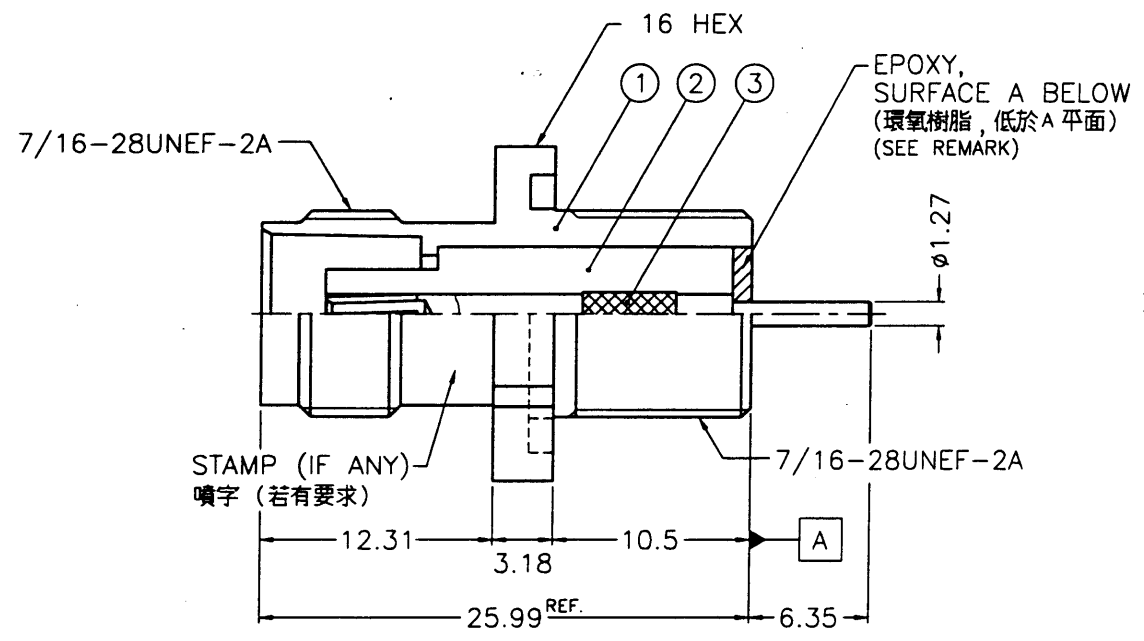

- NOTES: FINISH (PLATING THICKNESS IN MICRO-INCHES)
- BRASS PER QQ-8-626
  - PHOSPHOR BRONZE PER QQ-8-750
  - NICKEL PL. 100 MIN. THICK OVER COPPER STRIKE
  - GOLD PL. 30 MIN. THICK OVER NICKEL PL. 100 MIN. THICK OVER COPPER STRIKE
  - BERYLLIUM COPPER PER QQ-C-530
  - TEFLON MIL-P-19468

1. MAX. PANEL THICKNESS=7mm

DIMENSIONS ARE IN MILLIMETERS					PART NO.		<b>Amphenol - Kai Jack</b>		
UNLESS OTHERWISE SPECIFIED TOLERANCES					APPROVED		TAINAN TAIWAN		
6	HEX NUT	NOTE 1	NOTE 3	1	HN14-7/16-28X25	AOK C	DATE	09-09-02'	
5	LOCK WASHER	NOTE 2	NOTE 3	1	LW-1372/1119X05		CHECKED	DATE	09-09-02'
4	GASKET	SILICONE	RED	1	GS-144/11XD17	DRAWN	DATE	09-09-02'	
3	CONTACT PIN	NOTE 5	NOTE 4	1	CP01AKY01A	TITLE			
2	INSULATOR	NOTE 6	NATURAL	1	NS01AKG01A	TNC BULKHEAD RECEPT. JACK			
1	BODY	NOTE 1	NOTE 3	1	BD02ABV01A	DRAWING NO.			
					FILE NO.		KJ-T6351A3-001-NT30G-50		
					SCALE		ITEM NO.		
					2.5/1		026351AAF02NC5F		
					ISSUE		7RD-DR 154>88		
					A2				

1 2 3 4 5 6 7 8