

1 2 3 4 5 6 7 8

REVISIONS		
ISS	ZONE	DESCRIPTION\PER REQUEST\DATE

業務部

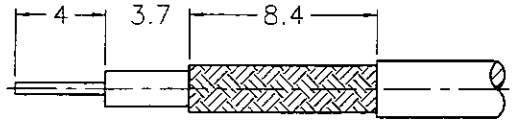

RECOMMENDED  
CABLE STRIPPING DIM'S

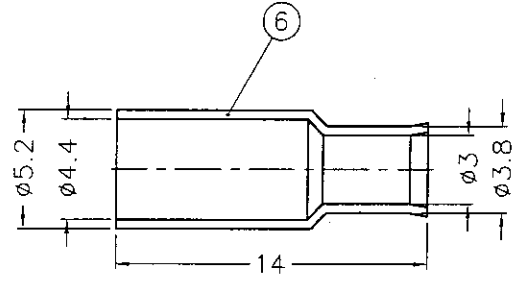
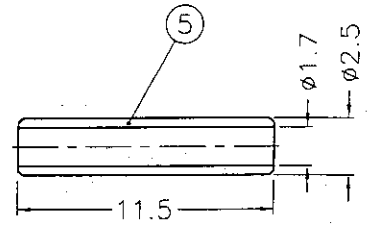
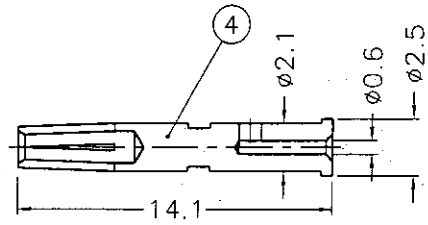
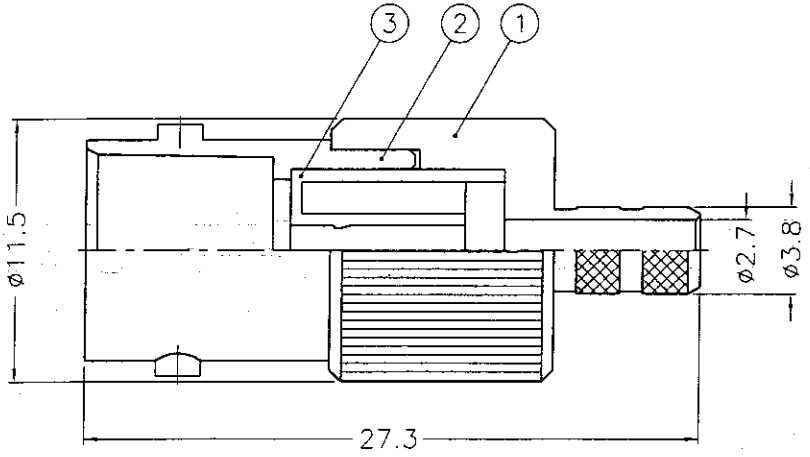

NOTES: FINISH (PLATING THICKNESS IN MICRO-INCHES)  
 1. BRASS PER QQ-B-626  
 2. NICKEL PL. 100 MIN. THICK OVER COPPER STRIKE  
 3. PHOSPHOR BRONZE PER QQ-B-750  
 4. GOLD PL. 3 MIN. THICK OVER NICKEL PL. 100 MIN. THICK OVER COPPER STRIKE  
 5. JIS H 3260, C 3501

出圖  
88.4.15  
R & D

NO.	DESCRIPTION	MATERIAL	FINISH	Q'TY	DRAWING NO.
6	FERRULE	NOTE 5	NOTE 2	1	FR-52/44-38/3 X14
5	SLEEVE	DELTRIN	NATURAL	1	SL-25/17X115
4	CONTACT PIN	NOTE 3	NOTE 4	1	B74000-8-25/06
3	INSULATOR	DELTRIN	NATURAL	1	B74050-3-75-B
2	BODY	NOTE 1	NOTE 2	1	B74000-2
1	HOUSING	NOTE 1	NOTE 2	1	B70002-1-38/27

DIMENSIONS ARE IN MILLIMETERS				PART NO.	
UNLESS OTHERWISE SPECIFIED TOLERANCES				APPROVED	
0.5-6	= ±0.2	DATE		04-13-99'	
6-30	= ±0.4	DATE		04-13-99'	
30-120	= ±0.6	DATE		04-13-99'	
120-315	= ±1	DATE		04-13-99'	
315-1000	= ±1.6	DATE		04-13-99'	
1000-2000	= ±2.4	DATE		04-13-99'	
SCALE	3/1	ISSUE	A	DRAWN	

<p>KAI JACK INDUSTRIAL CO., LTD. TAINAN TAIWAN R.O.C.</p>	
TITLE BNC CRIMP JACK	
DRAWING NO. KJ-B6121E1-ND3 G-316U-75	
FILE NO. F:\DWG\B\6121E1\316U-75\ND30G	

A

A

1 2 3 4 5 6 7 8 88R5367