

1 2 3 4 5 6 7 8

REVISIONS		
ISS	ZONE	DESCRIPTION\PER REQUEST\DATE
A1	A-7	B625100-014-NTS-50 WAS 050-1424-NTS-50\N/A \12-21-01'

SALES

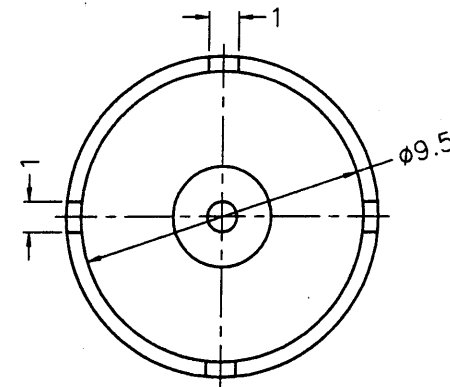
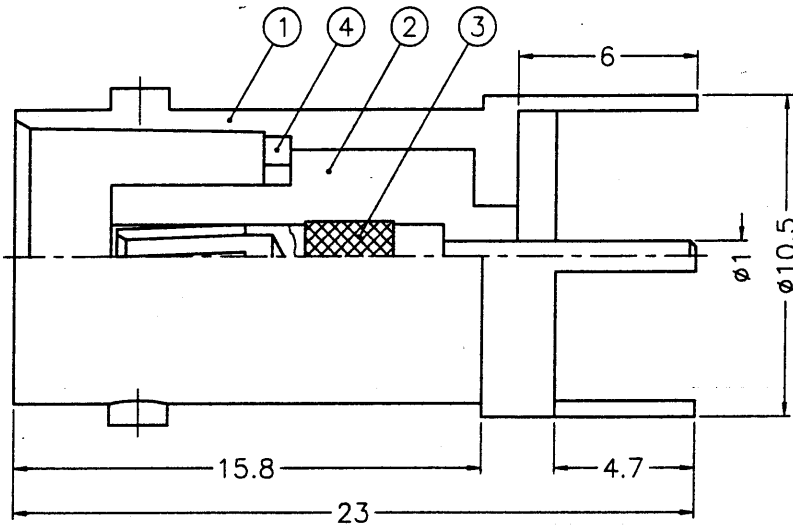

NOTES: FINISH (PLATING THICKNESS IN MICRO-INCHES)

- 1. BRASS PER QQ-B-626
- 2. NICKEL PL. 100 MIN. THICK OVER COPPER STRIKE
- 3. PHOSPHOR BRONZE PER QQ-B-750
- 4. SILVER PL. 200 MIN. THICK OVER COPPER STRIKE
- 5. TEFLON MIL-P-19468

ISSUED
2001. 12. 26
R&D

NO.	DESCRIPTION	MATERIAL	FINISH	Q'TY	DRAWING NO.
4	LOCK RING		NOTE 1	NOTE 2	1 LR-79/62X08
3	CONTACT PIN		NOTE 3	NOTE 4	1 050-1424-3
2	INSULATOR		NOTE 5	NATURAL	1 050-1424-2
1	BODY		NOTE 1	NOTE 2	1 050-1424-1-B

DIMENSIONS ARE IN MILLIMETERS	
UNLESS OTHERWISE SPECIFIED TOLERANCES	
0.5-6	= ±0.2
6-30	= ±0.4
30-120	= ±0.6
120-315	= ±1
315-1000	= ±1.6
1000-2000	= ±2.4

PART NO.	
APPROVED	<i>A. K. C.</i> DATE 12-20-01'
CHECKED	<i>Jacky</i> DATE 12-20-01'
DRAWN	<i>Ken</i> DATE 12-20-01'

Amphenol - Kai Jack TAINAN TAIWAN	
TITLE	BNC PCB JACK
DRAWING NO.	KJ-B625100-014-NTS-50
ITEM NO.	016251AAQ00NJ5F

1 2 3 4 5 6 7 RD-DR13473