

ISS	ZONE	DESCRIPTION \ PER REQUEST \ DATE
-----	------	----------------------------------

1	2	3	4	5	6	7	8
---	---	---	---	---	---	---	---

業務部

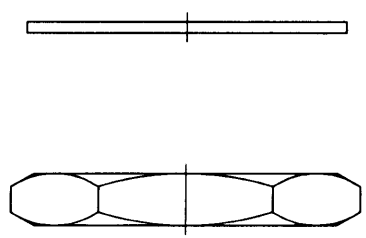
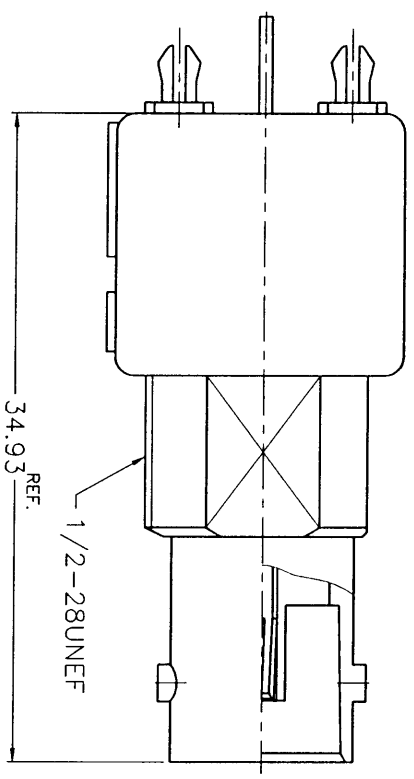
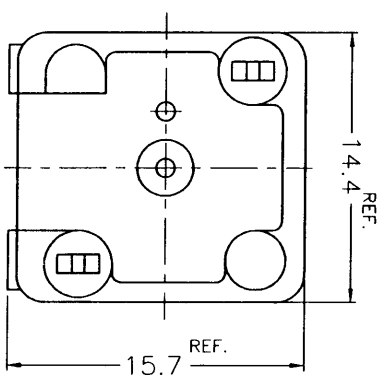
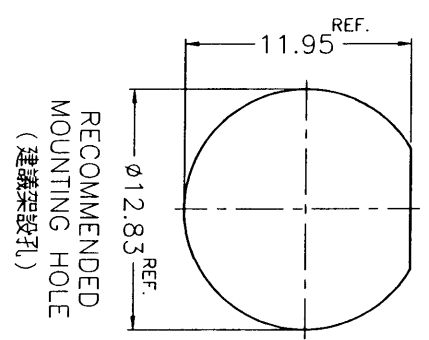
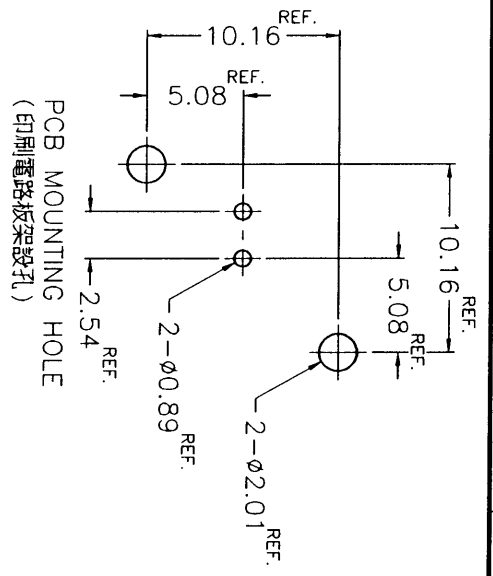

出圖
2012.16
設計部

1. MAX. PANEL THICKNESS=5mm

- NOTES: FINISH (PLATING THICKNESS IN MICRO-INCHES)
1. BRASS PER 00-B-626
 2. BRASS PER 00-B-613
 3. NICKEL PL. 100 MIN. THICK OVER ZINC ALLOY
 4. TIN PLATING
 5. PHOSPHOR BRONZE PER 00-B-750
 6. GOLD FLASH OVER NICKEL PL. 50 MIN. THICK AT MATING AREA.
 7. ZINC DIECAST
 8. POLYPROPYLENE UL 94HB

7	HEX NUT	NOTE 1	NOTE 3
6	LOCK WASHER	NOTE 2	NOTE 3
5	MOUNTING POST	NOTE 2	NOTE 4
4	POST	COPPER	NOTE 4
3	CONTACT PIN	NOTE 5	NOTE 6
2	INSULATOR	NOTE 8	NATURAL
1	BODY	NOTE 7	NOTE 3

DIMENSIONS ARE IN MILLIMETERS	
UNLESS OTHERWISE SPECIFIED	
0.5-6	= ±0.2
6-30	= ±0.4
30-120	= ±0.6
120-315	= ±1
315-1000	= ±1.6
1000-2000	= ±2.4

PART NO.	
APPROVED	<i>Andy C</i>
CHECKED	<i>Andy C</i>
DRAWN	<i>Andy C</i>
DATE	02-16-01
DATE	02-16-01
DATE	02-16-01

TITLE	
Amphenol - Kai Jack	
TAINAN TAIWAN	
BNC STRAIGHT PC MOUNT RECEPT. JACK	
DRAWING NO.	KJ-B6251G3-NPP3G-75T
FILE NO.	F:\DWG\B\6251G3\75T\NPP3G

1 2 3 4 5 6 7

RD-8R 11680