

業務部

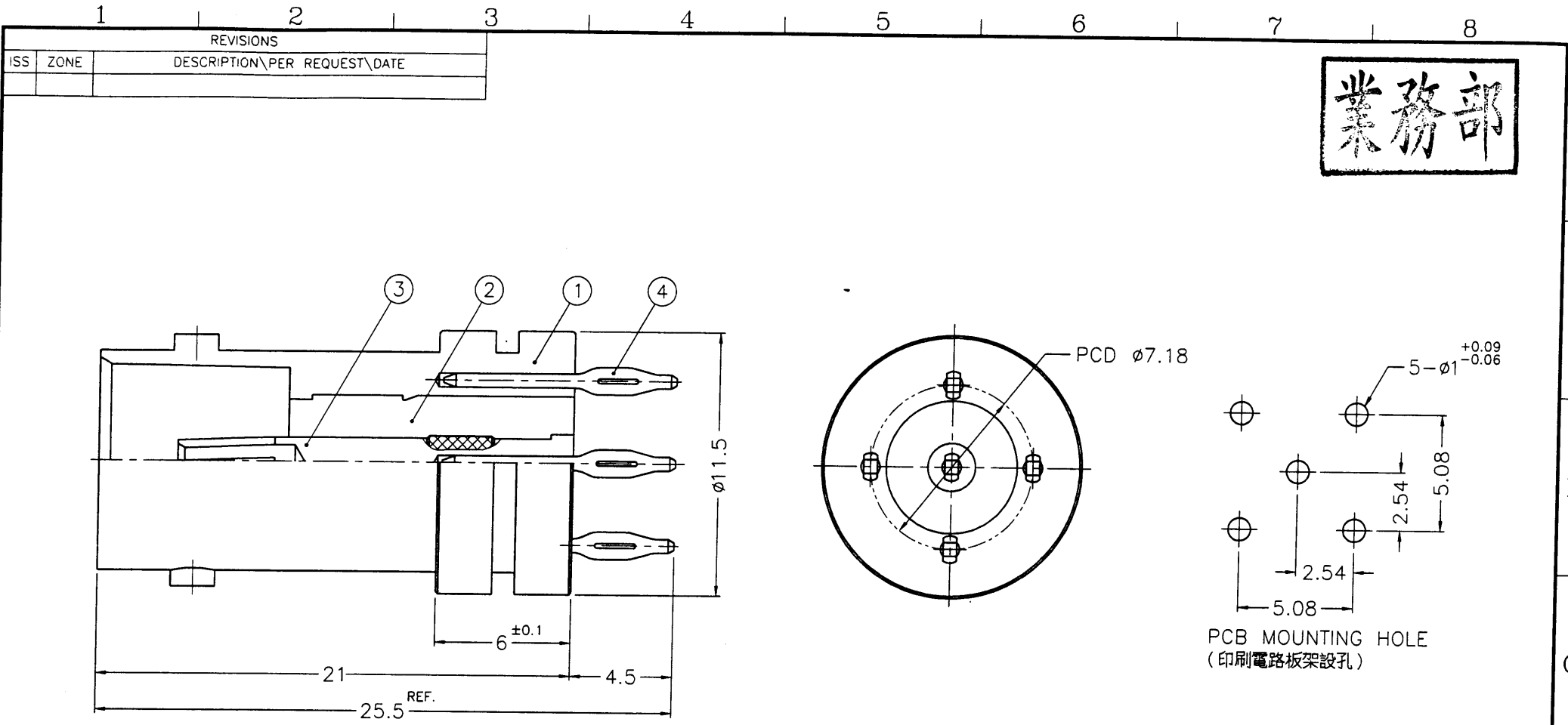

- NOTES: FINISH (PLATING THICKNESS IN MICRO-INCHES)
1. BRASS PER QQ-B-626
  2. NICKEL PL. 100 MIN. THICK OVER COPPER STRIKE
  3. PHOSPHOR BRONZE PER QQ-B-750
  4. GOLD PL. 10 MIN. THICK OVER NICKEL PL. 100 MIN. THICK OVER COPPER STRIKE
  5. TEFLON MIL-P-19468
  6. TIN-LEAD(90/10) PL. (120 MIN./200 MAX.) THICK OVER NICKEL PL. (80 MIN./120 MAX.) THICK

出圖  
89.4.10  
設計部

DIMENSIONS ARE IN MILLIMETERS				PART NO.			
UNLESS OTHERWISE SPECIFIED TOLERANCES				APPROVED <i>Andy.C</i> DATE 04-05-00'			
0.5-6 = ±0.2				CHECKED <i>Andy.C</i> DATE 04-05-00'			
6-30 = ±0.4				DRAWN <i>Gene L</i> DATE 04-05-00'			
30-120 = ±0.6							
120-315 = ±1							
315-1000 = ±1.6							
1000-2000 = ±2.4							

<b>Amphenol - Kai Jack</b> TAINAN TAIWAN	
TITLE BNC PRESS-FIT P.C.B. RECEPT. JACK	
DRAWING NO. KJ-B6251PF-001-NT10G-75	
FILE NO. F:\DWG\B\6251PF\001\75\NT10G	

NO.	DESCRIPTION	MATERIAL	FINISH	Q'TY	DRAWING NO.
4	LEG		NOTE 3	NOTE 6	5 4M-283-01
3	CONTACT PIN		NOTE 3	NOTE 4	1 B6251PF-001-3
2	INSULATOR		NOTE 5	NATURAL	1 B6251PF-001-2T-75
1	BODY		NOTE 1	NOTE 2	1 B6251PF-001-1

920