

REVISIONS		
ISS	ZONE	DESCRIPTION\PER REQUEST\DATE
A1	F-7	ADDED A DETAIL\N/A\07-06-01'

SALES

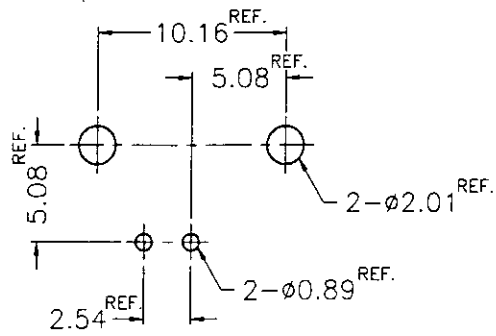

PCB MOUNTING HOLE
(印刷電路板架設孔)

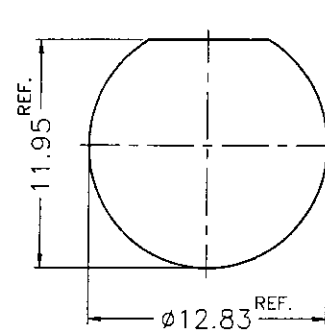

RECOMMENDED MOUNTING HOLE
(建議架設孔)

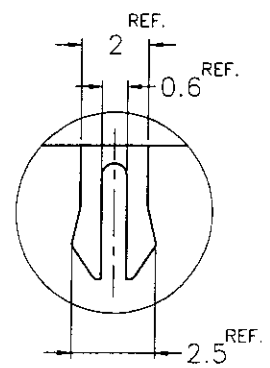

A DETAIL (5/1)
(A 詳圖)

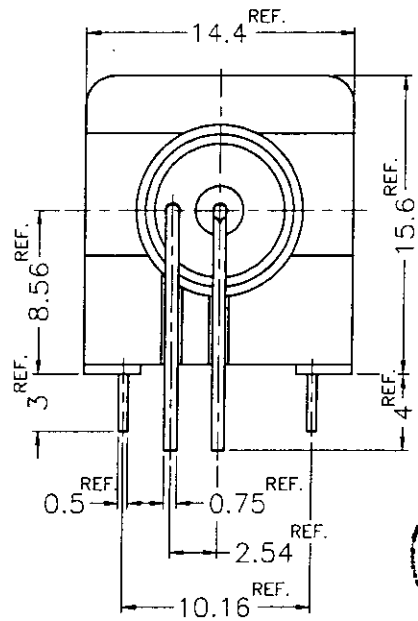

1. MAX. PANEL THICKNESS=5mm

ISSUED
2001. 7. 12
R&D

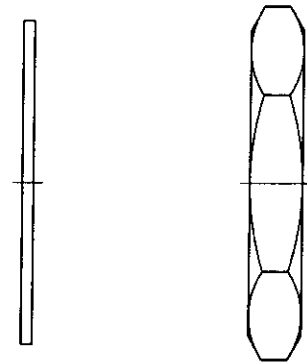
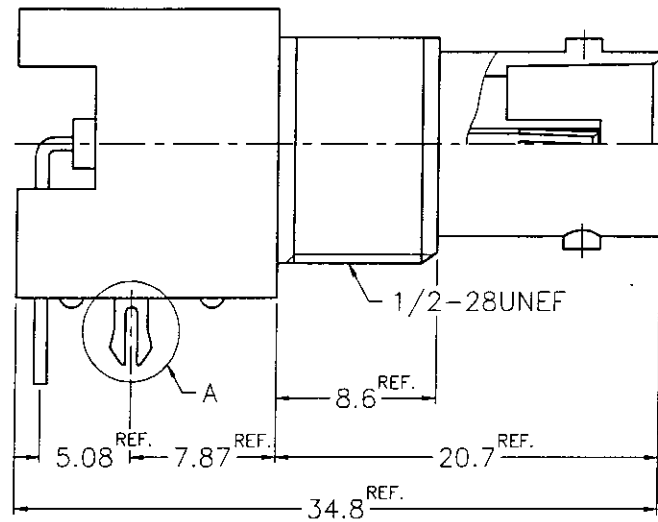

- NOTES: FINISH (PLATING THICKNESS IN MICRO-INCHES)
- BRASS PER QQ-B-626
 - BRASS PER QQ-B-613
 - NICKEL PL. 100 MIN. THICK OVER ZINC ALLOY
 - TIN PLATING
 - PHOSPHOR BRONZE PER QQ-B-750
 - GOLD FLASH OVER NICKEL PL. 50 MIN. THICK AT MATING AREA.
TIN-LEAD PL. 100 MIN. THICK OVER NICKEL PL. 50 MIN. THICK AT TAIL.
 - ZINC DIECAST
 - POLYPROPYLENE UL 94HB
 - PBT (UL 94 V-0)

NO.	DESCRIPTION	MATERIAL	FINISH	Q'TY	DRAWING NO.
8	HEX NUT				
7	LOCK WASHER				
6	MOUNTING POST				
5	POST	COPPER			
4	CONTACT PIN				
3	INSULATOR		NATURAL		
2	BODY		WHITE		
1	HOUSING				

DIMENSIONS ARE IN MILLIMETERS			
UNLESS OTHERWISE SPECIFIED TOLERANCES			
0.5-6	=	±0.2	
6-30	=	±0.4	
30-120	=	±0.6	
120-315	=	±1	
315-1000	=	±1.6	
1000-2000	=	±2.4	

PART NO.	
APPROVED	DATE 07-06-01'
CHECKED	DATE 07-06-01'
DRAWN	DATE 07-06-01'

Amphenol - Kai Jack	
TAINAN TAIWAN	
TITLE BNC R/A PC MOUNT RECEPT. JACK	
DRAWING NO. KJ-B6252H5-NPP3G-75T	
FILE NO. F:\DWG\B\6252H5\75T\NPP3G	

RD-DR12493