

REVISIONS		
ISS	ZONE	DESCRIPTION\PER REQUEST\DATE
A1	ALL	DIMENSIONS WERE CHANGED\N/A\11-07-01'
A2	ALL	DIMENSIONS WERE CHANGED\N/A\05-03-02'

SALES

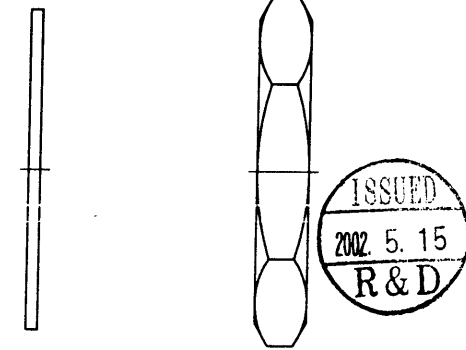
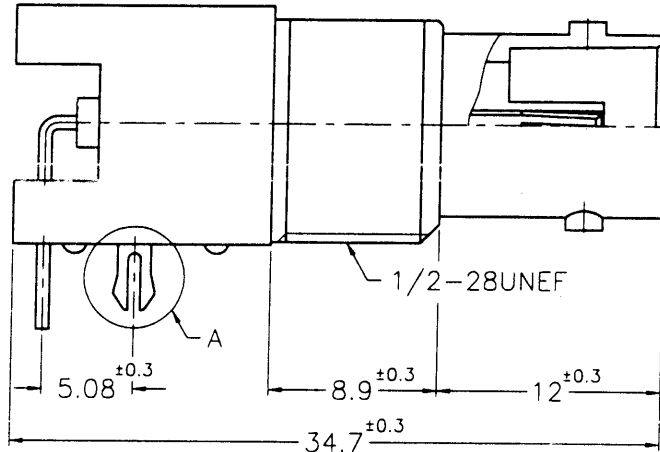
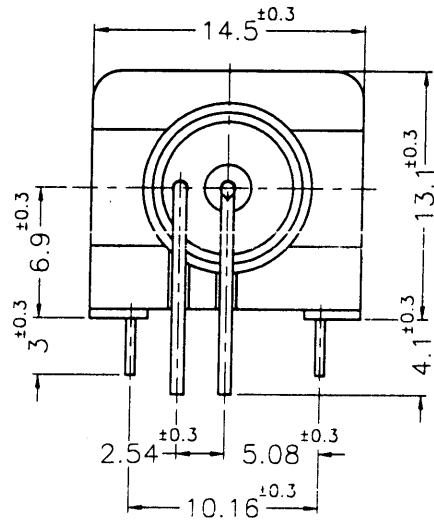
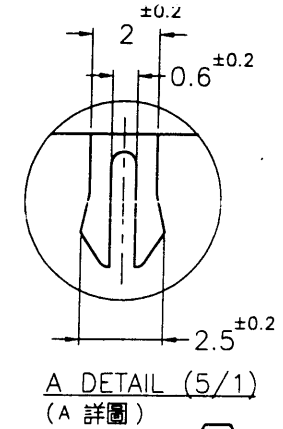
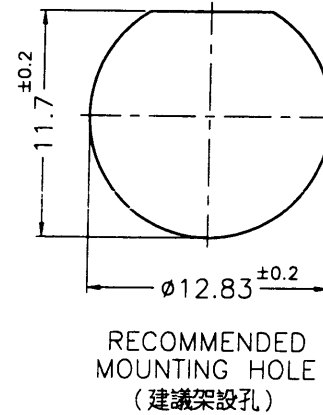
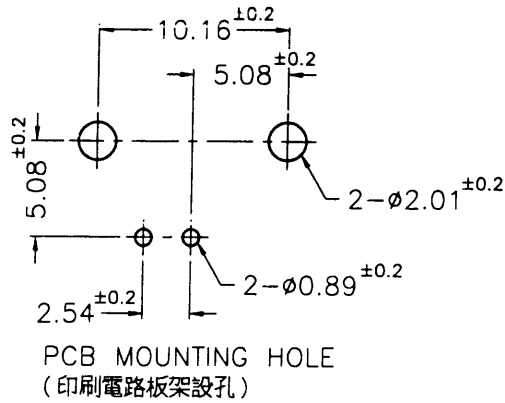

- NOTES: FINISH (PLATING THICKNESS IN MICRO-INCHES)
- BRASS PER QQ-B-626
 - BRASS PER QQ-B-613
 - NICKEL PL. 100 MIN. THICK OVER ZINC ALLOY
 - TIN PLATING
 - PHOSPHOR BRONZE PER QQ-B-750
 - GOLD FLASH OVER NICKEL PL. 50 MIN. THICK AT MATING AREA.
 - TIN-LEAD PL. 100 MIN. THICK OVER NICKEL PL. 50 MIN. THICK AT TAIL.
 - ZINC DIECAST
 - POLYPROPYLENE UL 94HB
 - PBT (UL 94 V-0)
 - NICKEL PL. 80 MIN. THICK OVER COPPER STRIKE

ISSUED
2002.5.15
R&D

1. MAX. PANEL THICKNESS=5mm

NO.	DESCRIPTION	MATERIAL	FINISH	Q'TY	DRAWING NO.
	HEX NUT		NOTE 1	NOTE 10	
	LOCK WASHER	S50C	NOTE 10		
	MOUNTING POST		NOTE 2	NOTE 4	
	POST	COPPER	NOTE 4		
	CONTACT PIN		NOTE 5	NOTE 6	
	INSULATOR		NOTE 8	NATURAL	
	BODY		NOTE 7	NOTE 3	
	HOUSING		NOTE 9	WHITE	

DIMENSIONS ARE IN MILLIMETERS				PART NO.	
UNLESS OTHERWISE SPECIFIED TOLERANCES				APPROVED	DATE
0.5-6	=	±0.2		<i>Mark C</i>	05-03-02'
6-30	=	±0.4			
30-120	=	±0.6		CHECKED	DATE
120-315	=	+1		<i>Karl J.</i>	05-03-02'
315-1000	=	±1.6		DRAWN	DATE
1000-2000	=	±2.4		<i>Angela W.</i>	05-03-02'
SCALE	2.5/1	ISSUE	A2	FILE NO.	F:\DWG\B\6252H7\75T\NPP3G

Amphenol - Kai Jack	
TAINAN TAIWAN	
TITLE	BNC R/A PC MOUNT RECEPT. JACK
DRAWING NO.	KJ-B6252H7-NPP3G-75T
ITEM NO.	016252AAC07MB0F

7RD-TR 144198