

REVISIONS		
ISS	ZONE	DESCRIPTION\PER REQUEST\DATE
A1	ALL	DIMENSIONS WERE CHANGED\N/A\02-16-01'
A2	C-2	DIMENSIONS WERE CHANGED\N/A\03-14-01'
A3	ALL	DIMENSIONS WERE CHANGED\N/A\05-03-02'
A4	A-7	ITEM NO. WAS CHANGED\N/A\05-03-02'

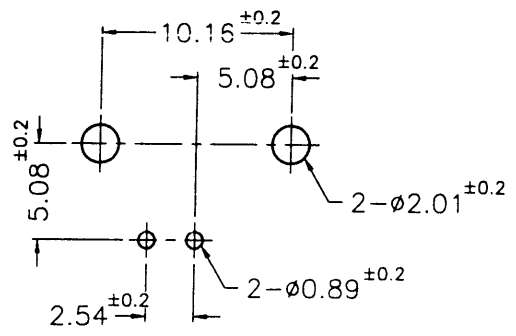

PCB MOUNTING HOLE
(印刷电路板架設孔)

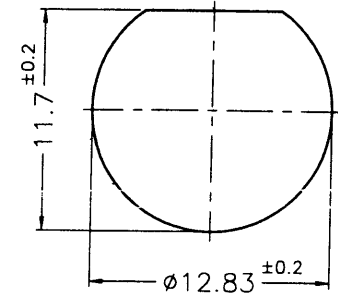

RECOMMENDED MOUNTING HOLE
(建議架設孔)

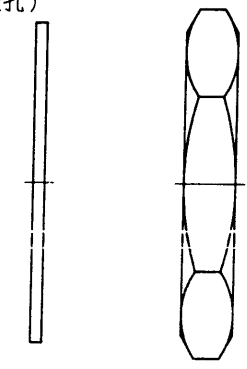
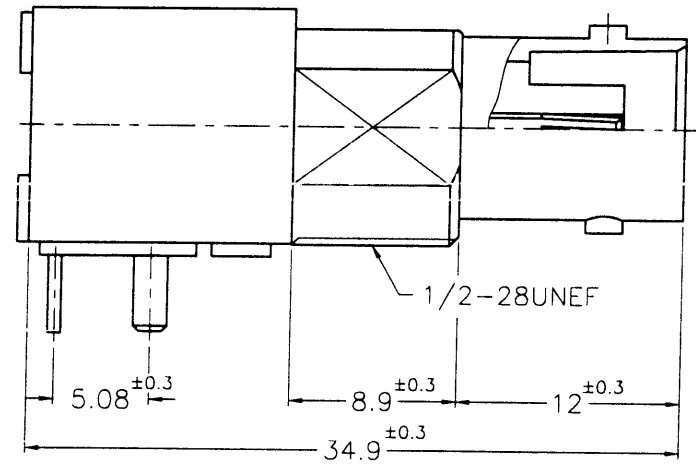
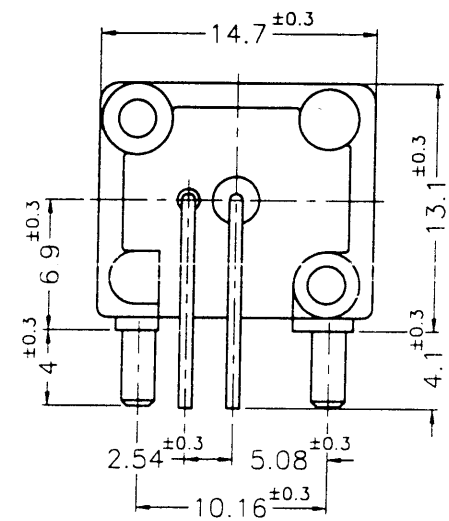

- NOTES: FINISH (PLATING THICKNESS IN MICRO-INCHES)
- BRASS PER QQ-B-626
 - NICKEL PL. 80 MIN. THICK OVER COPPER STRIKE
 - NICKEL PL. 100 MIN. THICK OVER ZINC ALLOY
 - PHOSPHOR BRONZE PER QQ-B-750
 - GOLD FLASH AT MATING AREA
 - TIN-LEAD PL. 100 MIN. THICK AT TAIL.
 - ZINC DIECAST
 - POLYPROPYLENE UL 94HB
 - TIN PLATING



MAX. PANEL THICKNESS=5mm

DIMENSIONS ARE IN MILLIMETERS				PART NO.	
UNLESS OTHERWISE SPECIFIED TOLERANCES				APPROVED <i>[Signature]</i> DATE 05-20-02'	
0.5-6 = ±0.2				CHECKED <i>[Signature]</i> DATE 05-20-02'	
6-30 = ±0.4				DRAWN <i>[Signature]</i> DATE 05-20-02'	
30-120 = ±0.6				FILE NO. F:\DWG\B\6252HB\50\NPP3G-1	
120-315 = ±1					
315-1000 = ±1.6					
1000-2000 = ±2.4					

Amphenol - Kai Jack	
TAINAN TAIWAN	
TITLE BNC R/A PC MOUNT RECEPT. JACK	
DRAWING NO. KJ-B6252HB-NPP3G-50	
ITEM NO. 016252AAF07MB5F	

NO.	DESCRIPTION	MATERIAL	FINISH	Q'TY	DRAWING NO.
	HEX NUT		NOTE 1	NOTE 2	
	LOCK WASHER	SS0C	NOTE 2	NOTE 2	
	MOUNTING POST		NOTE 1	NOTE 8	
	POST	COPPER	NOTE 8	NOTE 8	
	CONTACT PIN		NOTE 4	NOTE 5	
	INSULATOR		NOTE 7	NATURAL	
	BODY		NOTE 6	NOTE 3	