

REVISIONS		
ISS	ZONE	DESCRIPTION\PER REQUEST\DATE

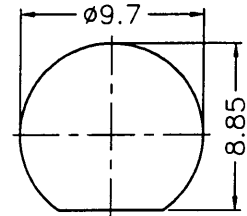

RECOMMENDED MOUNTING HOLE (建議架設孔)

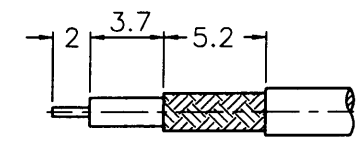

RECOMMENDED CABLE STRIPPING DIM'S (建議剝線尺寸)

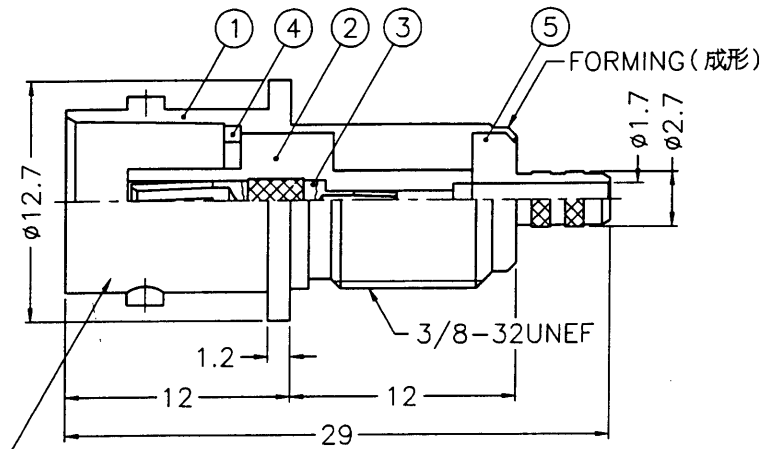

STAMP (IF ANY) 噴字 (若有要求)

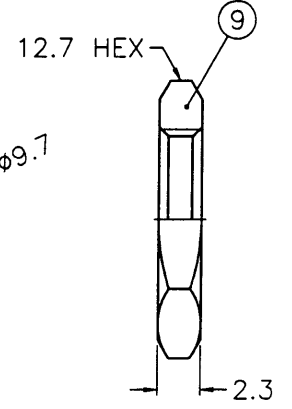
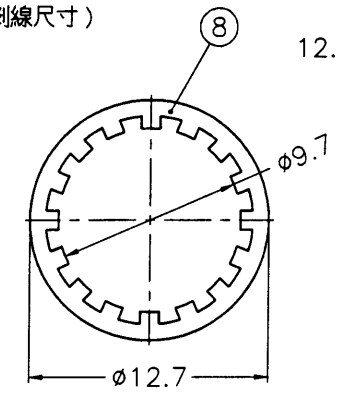
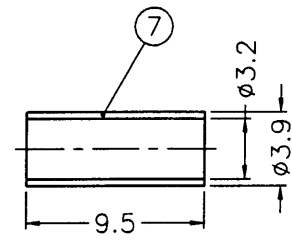
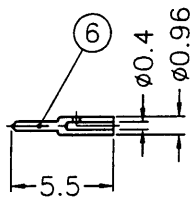

- NOTES: FINISH (PLATING THICKNESS IN MICRO-INCHES)
- BRASS PER QQ-B-626
 - BRASS PER QQ-B-613
 - NICKEL PL. 100 MIN. OVER COPPER STRIKE
 - PHOSPHOR BRONZE PER QQ-B-750
 - GOLD PL. 3 MIN. OVER NICKEL PL. 100 MIN. OVER COPPER STRIKE
 - TEFLON MIL-P-19468
 - JIS H 3250, C 2700

- CRIMPED FERRULE
HEX CRIMP SIZE .128"
- CRIMPED CONTACT PIN
SQ. CRIMP SIZE 0.7(mm)
- MAX. PANEL THICKNESS=7.5mm



NO.	DESCRIPTION	MATERIAL	FINISH	Q'TY	DRAWING NO.
9	HEX NUT	NOTE 1	NOTE 3	1	HN127-3/8-32X23
8	LOCK WASHER	NOTE 2	NOTE 3	1	LW-127/97X05
7	FERRULE	NOTE 7	NOTE 3	1	FR-39/32X95
6	CONTACT PIN	NOTE 1	NOTE 5	1	112587-6-096/04
5	BARREL	NOTE 1	NOTE 3	1	112587-5
4	LOCK RING	NOTE 2	NOTE 3	1	B7700-4
3	CONTACT PIN	NOTE 4	NOTE 5	1	112587-3
2	INSULATOR	NOTE 6	NATURAL	1	112587-2-75T
1	BODY	NOTE 1	NOTE 3	1	112587-1

DIMENSIONS ARE IN MILLIMETERS		PART NO.	
UNLESS OTHERWISE SPECIFIED TOLERANCES		APPROVED	DATE
0.5-6 = ±0.2		<i>Carol W</i>	06-08-01'
6-30 = ±0.4		CHECKED	DATE
30-120 = ±0.6		<i>Carol W</i>	06-08-01'
120-315 = ±1		DRAWN	DATE
315-1000 = ±1.6		<i>Angela Wu</i>	06-08-01'
1000-2000 = ±2.4			
SCALE 2.5/1	ISSUE A		

Amphenol - Kai Jack TAINAN TAIWAN	
TITLE	BNC BULKHEAD CRIMP JACK
DRAWING NO.	KJ-B6321A2-003-NT3G-179U-75T
FILE NO.	F:\DWG\B\6321A2\003\179U-75T\NT3G

F
E
D
C
B
A

F
E
I
C
E
A